

AIXIA
www.aixia.es



CATÁLOGO

2025

**Nuestro mundo,
la herramienta neumática**



Aixia, S.A. nace en 1.974 apostando por el uso de la herramienta neumática en todas sus aplicaciones. En la actualidad, somos una empresa de referencia en nuestro sector, siendo especialistas en la comercialización y reparación de herramientas neumáticas, y ofreciendo a nuestros clientes la máxima CALIDAD y SERVICIO.

Disponemos de una amplia gama de productos para poder adaptarnos a las necesidades del cliente, con más de 250 modelos de herramientas (llaves de impacto, atornilladores, remachadoras, taladros, lijadoras, etc.) y más de 1.500 referencias de accesorios de alta calidad para llegar a un amplio abanico de aplicaciones en sectores como automoción, mantenimiento y diferentes servicios industriales.

Nuestra experiencia y compromiso hacen que consigamos, en la mayoría de los casos, reparar las herramientas en un plazo máximo de 24 horas.

Contamos con un gran almacena-je y un amplio stock para garantizar un servicio rápido a nuestros clientes.

Si la herramienta o accesorio que usted necesita, no la encuentra en nuestro catálogo o página web, no dude en consultarnos y le ayudaremos a buscar la mejor solución o alternativa posible.

Por último, AIXIA, S.A. ha implantado, gracias a su equipo humano, un Sistema de Gestión de la Calidad para la consecución de nuestros objetivos, según la Norma ISO 9001.



Expositores de herramientas

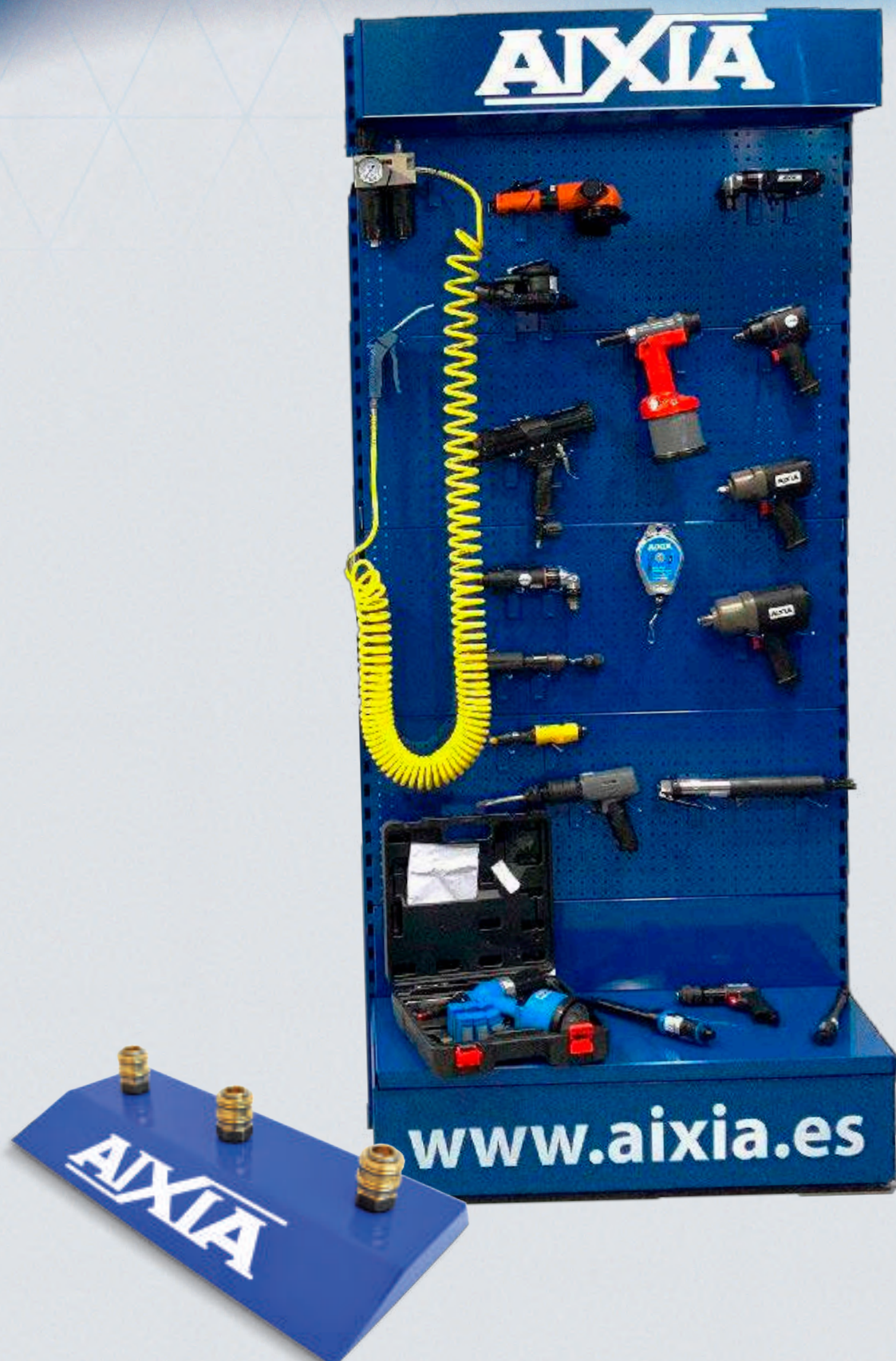

01



Enchufes, racordaje y accesorios

Pág. 6

02



Máquinas con eje de cuadradillo

Pág. 56

03



Máquinas para montaje

Pág. 84

04



Máquinas para abrasión

Pág. 120

05



Martillos y varios

Pág. 152

Índice alfabético

A



Alicates, Tijeras
157-158



Amoladoras
134-147



Atornilladores
96-103

C



Carracas
58-61



Cinceles
174-175



Clavadoras y grapadoras
154-155



Conexiones instantáneas
41-43



Cortadoras
164-165



Cuchillas
159-161

D



Desbarbadoras
148-151

E



Enchufes rápidos
12-37



Enrolladores de manguera
47-48



Equilibradores
92-95

F



Filtraje y lubricación
8-11

I



Infladores de ruedas
57

L



Lápiz grabador
134



Lijadoras y pulidoras
122-133



Llaves de impacto
62-75

M



Máquinas electroportátiles
176-177



Mangueras y espirales
44-46



Martillos, martilletes, pisones
167-173



Motores neumáticos
113

P



Pistolas de pintar
52



Pistolas de soplar
49-52



Pistolas sellantes
53-54



Puntas de atornillar
86-91

Q



Quita adhesivos
166



Quitapunas
163



Quitapuntos y biseladora
162

R



Racordaje
38-40



Remachadoras
114-119



Roscadoras
112-113

S



Sierras, podadora y limas
155-157

T



Taladros
104-111

V



Vasos de impacto
76-83



Enchufes, racordaje y accesorios

01



Filtraje y lubricación	8
Enchufes	12
Racordaje	38
Conexiones instantáneas	41
Tubo, mangueras y espirales	44
Enrolladores	47
Pistolas de soplar, aspirar, pintar, petroleo y sellar	49
Infladores	55



Filtraje



MODELO	CAUDAL
F-1/4	1.720
F-3/8	4.100
F-1/2	4.100
F-3/4	11.000
F-1	11.000



MODELO	CAUDAL
L-1/4	1.100
L-3/8	4.300
L-1/2	4.300
L-3/4	16.000
L-1	16.000



Incluye manómetro

MODELO	CAUDAL
R-1/4	700
R-3/8	2.500
R-1/2	2.500
R-3/4	4.500
R-1	4.500



Incluye manómetro

MODELO	CAUDAL
FR-1/4	700
FR-3/8	2.500
FR-1/2	2.500



Incluye manómetro

MODELO	CAUDAL
FR+L-1/4	700
FR+L-3/8	2.200
FR+L-1/2	2.200



Incluye manómetro

MODELO	CAUDAL
FRL-1/4	700
FRL-3/8	2.500
FRL-1/2	2.500
FRL-3/4	4.500
FRL-1	4.500

FILTRO ESPECIAL CABINAS DE PINTURA

MODELO	CAUDAL
FR+D 1/2	2.200

El primer cuerpo filtra las partículas mayores de 20 μm y el segundo depura las partículas mayores de 0,01 μm dejando el aire en condiciones óptimas para la aplicación de pinturas.

- Incluye manómetro





Filtraje



Desde Aixia recomendamos instalar este tipo de elementos en el tubo bajante de su instalación de aire y hacerles un mantenimiento preventivo constante, comprobando la regulación de la presión de trabajo y el nivel de lubricante en el vaso.

- Campo de regulación: 0-12 BAR
- Grado de filtración: 20 μ m
- Presión máxima de entrada: 18 BA
- Purga: semiautomática por descenso de presión a 1,5 bar
- Presión mínima: para correcto funcionamiento 1,5 bar



Incluye manómetro

MODELO	CAUDAL
F-AZ-1/4	1.720
F-AZ-3/8	4.100
F-AZ-1/2	4.100

MODELO	CAUDAL
L-AZ-1/4	1.100
L-AZ-3/8	4.300
L-AZ-1/2	4.300

MODELO	CAUDAL
R-AZ-1/4	700
R-AZ-3/8	2.500
R-AZ-1/2	2.500



Incluye manómetro

Incluye manómetro

Incluye manómetro

MODELO	CAUDAL
FR-AZ-1/4	700
FR-AZ-3/8	2.500
FR-AZ-1/2	2.500

MODELO	CAUDAL
FR+L-AZ-1/4	700
FR+L-AZ-3/8	2.200
FR+L-AZ-1/2	2.200

MODELO	CAUDAL
FRL-AZ-1/4	700
FRL-AZ-3/8	2.500
FRL-AZ-1/2	2.500



Filtraje skillair



Material ligero
Mayor precisión

- Campo de regulación: 0-12 BAR
- Grado de filtración: 20 µm
- Presión máxima de entrada: 13 BAR
- Purga: Semiautomática por descenso de presión a 1,5 bar
- Presión mínima: Para correcto funcionamiento 1,5 bar



MODELO	CAUDAL
FSK-1	5.300

Incluye manómetro



MODELO	CAUDAL
RSK-1	7.000

Incluye manómetro



MODELO	CAUDAL
LSK-1	5.500



MODELO	CAUDAL
FRSK-1	5.000

Incluye manómetro



MODELO	CAUDAL
FR+LSK-1	4.000

ACEITE ESPECIAL PARA HERRAMIENTA NEUMÁTICA SAE 5



Lubricar adecuadamente las máquinas alarga sustancialmente su vida útil; compruebe siempre el nivel de lubricación de sus instalaciones.

ASPECTO: Líquido transparente
OLOR: Característico
PUNTO DE INFLAMACIÓN: 195°C min.
DENSIDAD RELATIVA: 0,86 gr/cc a 20°C
SOLUBILIDAD: Insoluble en agua
VISCOSIDAD: 15 cSt a 40°C

PUNTO DE CONGELACIÓN: -25°C max
COLOR: Amarillento (<1)

CUMPLE ESPECIFICACIONES DE NORMA:

- ISO/TR 6743, categorías FC y FD
- DIN 51524 parte 3, categoría HL
- DIN 51517 parte 3, categoría CL

MODELO	CONTENIDO
BA-2L	2 l
BA 1/4L	1/4 l



Accesorios y lubricación

MANÓMETRO



MODELO	ROSCA
MANOMETRO	1/8

SOPORTE DE PARED



MODELO	GRUPO
R9200701	1/4
R9400701	3/8 - 1/2

LUBRICADOR



MODELO	ROSCA
STB	1/4

REGULADOR



MODELO	ROSCA	Ø
BR-02	1/4	1/4

DG1407 REGULADOR DIGITAL

Adecuado para el funcionamiento de herramientas neumáticas.

- **Duradero y eficiente:** Resistente, ligero y de aluminio.
- **Manómetro de aire digital avanzado:** mediciones de presión precisas.
- **Unidades de presión múltiple:** PSI, Bar, kg/cm² y Kpa con función de apagado automático.
- **Diseño robusto:** carcasa resistente a los impactos para condiciones difíciles.
- **Portátil y fácil de usar:** ligero con batería reemplazable.



MATERIAL: Aluminio

ENTRADA Y SALIDA DE AIRE:

1/4" con conector giratorio

RANGO MEDIDAS DE PRESIÓN: 0-160 PSI,

0-11 BAR, 0-11 Kg/cm², 0-1,100 Kpa

PILAS REEMPLAZABLES: Sí (CR2032)

APAGADO AUTOMÁTICO: Sí

PESO: 0,25 kgs.



Enchufes rápidos

 En algunos enchufes será necesario hacer pedido de cajas completas

INFORMACIÓN SOBRE ENCHUFES RÁPIDOS

Todo nuestro sistema de aire, desde el compresor hasta la herramienta, tiene un solo fin, conseguir el máximo rendimiento de la herramienta neumática con el menor coste posible. Según el enchufe rápido que utilice, puede facilitar o impedirlo.

Un enchufe rápido con válvula ULTRA-FLO, tiene un rendimiento entre un 60 y un 80 % superior (mayor paso de aire y menor caída de presión) que uno convencional, mejorando notablemente el rendimiento de la herramienta y de la instalación de aire.

En los enchufes de pared, se recomienda instalar enchufes de seguridad, evitan accidentes y facilitan la conexión-desconexión.

Una caída de presión de 1 bar, supone reducir el rendimiento de la herramienta hasta un 26 %.

Coloque un latiguillo de 0,5 m, entre la herramienta y el enchufe rápido, con ello evitará que se transmitan las vibraciones de la herramienta al enchufe y dañen la válvula del mismo, provocando costosas fugas de aire.

Tipos de enchufes rápidos

ENCHUFES CON VÁLVULA ULTRA-FLO

Las series 17, 18, 23, 1400, 25, 1600, 27, 1700, 1300, 1800, 33, 34 tienen válvula ULTRA-FLO, tanto las series KA, como las de seguridad KE.

ENCHUFES DE SEGURIDAD O ANTILATIGAZO

Se recomienda instalarlos sobre todo a la salida del FRL, le ayudará a prevenir accidentes y le facilitará la conexión-desconexión y llevan incorporada la válvula ULTRA-FLO. Series : 24KE, 1600KE, 26KE, A028, 24KP, 26KP, 30KP, A030, A037.

ENCHUFES INOXIDABLES

Series 20, 21, 24, 25, 26, 27, 70. Pueden suministrarse en acero inoxidable. Consulte disponibilidad y precios.

ENCHUFES PARA GASES

Series 21-KEY, 25-KEY. Tienen perfiles no intercambiables y colores diferenciadores para evitar conexiones indeseadas.

ENCHUFES PARA MOLDES

Series 86, 87, 88. Pueden suministrarse con paso libre o con válvula. Se usan para refrigerar moldes de inyección.

ENCHUFES PARA AGUA A PRESIÓN

Series 41, 42, 45. No tienen válvula y pueden soportar hasta 150 bar y 200°C, según series. Consulte disponibilidad y precios.

ENCHUFES CON DOBLE CIERRE

Series 20, 21, 25, 26, 27, 38, 39. Pueden suministrarse con válvula de doble cierre. Consulte disponibilidad y precios.

ENCHUFES ESPECIALES

RECTUS tiene un extenso programa con soluciones para cualquier tipo de conexión de fluidos y de gases, si no encuentra en este catálogo lo que necesita, no dude en ponerse en contacto con nosotros.

Perfil de los racores

ESCALA 1:1

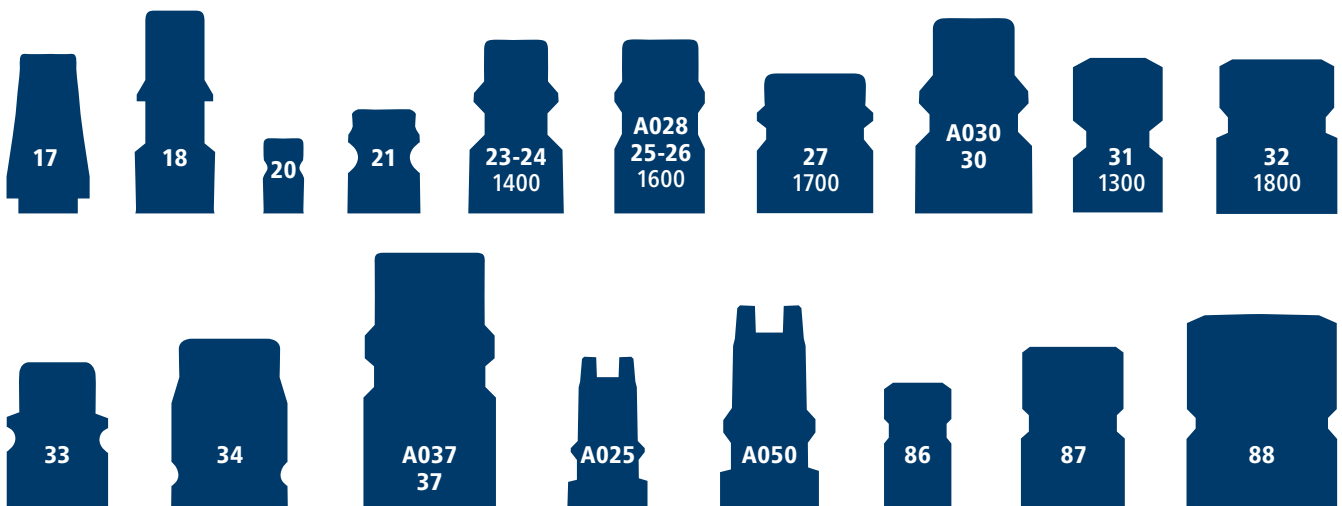



Enchufes rápidos



RESUMEN DE LAS ESPECIFICACIONES DE PRODUCTO

¿Cuales son sus condiciones de uso?

MATERIALES DEL ENCHUFE

Acero inoxidable.
AISI 303 o 306L. Para los medios agresivos. Alta resistencia a la corrosión.

Latón/Acero.
Principalmente para aplicaciones neumáticas.

Termoplástico.
POM / PVDF. Para todo tipo de medios, por ejemplo, fluidos químicos.

MATERIALES DE LAS JUNTAS

Dependiendo del medio

- NBR: -20°C hasta +100°C
- EPDM: -40°C hasta +150°C
- FKM: -15°C hasta +200°C
- FFKM: -25°C hasta +240°C

¿QUÉ FUNCIÓN Y CONTROL DE FLUJO NECESITA?

La dirección de cierre siempre se define por la combinación de acoplamientos y enchufes.

 **KF**
SIN OBTURACIÓN

- Mejor caudal/sin turbulencias
- Ideal para el uso de líquidos

 **KA**
SIMPLE OBTURACIÓN

- El enchufe es directo
- El caudal es detenido por la válvula dentro del acoplador durante la desconexión.



- Válvula estándar
- Diseño robusto y compacto



- Válvula de alto caudal
- El flujo aumenta hasta un 80% en comparación con los sistemas tradicionales debido a la menor turbulencia.



- Válvula de caudal ultra alto
- La válvula de alta gama extremadamente aerodinámica garantiza un flujo óptimo y se puede encontrar en nuestra serie de ahorro de energía.

 **KB**
DOBLE OBTURACIÓN

- Válvulas de cierre en el enchufe y el racor automático.
- La presión se mantiene en ambos lados.

 **KL**
DOBLE OBTURACIÓN SIN GOTEO

El enchufe y el enchufe automático tienen una válvula plana ideal para evitar que las gotas del medio se escapen.

¿QUÉ MEDIDAS DE SEGURIDAD NECESITA?

 **KS**
SIMPLE OBTURACIÓN

- Enchufe de seguridad
- El mecanismo de bloqueo de seguridad evita la desconexión involuntaria.

 **KS**
AIRE RESPIRABLE

 **KD**
DOBLE OBTURACIÓN

 **KE**
SISTEMAS DE DESCOMPRESIÓN

- Enchufe de seguridad con un sistema de descompresión.
- No hay desconexión involuntaria ni efecto de latigazo para evitar el riesgo de accidentes de trabajo.

 **KE**
SISTEMAS DE DESCOMPRESIÓN A BOTON

 **KS**
SISTEMAS CODIFICADOS

- Enchufe de seguridad mecánica y código de colores.
- Evite las confusiones entre los medios al acoplar.

¿QUÉ CONEXIÓN FINAL NECESITAS?

Conexión de la manguera

Conexión roscada

La conexión del tubo de plástico

¿CUAL ES SU ENTORNO DE APLICACIÓN?

LA PRESIÓN: Presión del sistema, picos de presión.

TEMPERATURA: Medio, Medio ambiente, Operación/Parada.

MEDIO: Aire comprimido, vacío, agua/agua de mar, otros fluidos/gases.

LA TASA DE CAUDAL: Flujo de volumen, viscosidad media, conexión final.

ENTORNO OPERATIVO: Calidad del aire ambiente (contaminación), riesgo de choques, áreas confinadas/dificultades de acceso, uso de productos en equipos móviles, atmósfera corrosiva.

¿QUÉ PERFIL DE INTERCAMBIABILIDAD NECESITA?

ISO B

ISO C

EURO

ARO

REINO UNIDO

SCANDIC

ASIA



Enchufes rápidos

IDENTIFICACIÓN DEL NÚMERO DE PIEZA



ACOPLAMIENTOS

KA = Simple obturación
KB = Doble obturación
KF = Sin obturación
KL = Doble obturación sin goteo
KE = Sistema de descompresión
KP = Pulsador
KS = Seguridad (Simple obturación)
KD = Seguridad (Doble obturación)
KR = Seguridad (Sin obturación)

SF = Sin obturación
SB = Doble obturación
SL = Doble obturación sin goteo
SS = Seguridad (Sin obturación)
SD = Seguridad (Doble obturación)
SR = Eliminador de retroceso

PLUGS

ROSCA MÉTRICA

05 = M5
10 = M10x1
12 = M12x1,5
14 = M14x1,5
16 = M16x1,5
18 = M18x1,5

10 = 1/8"
13 = 1/4"
17 = 3/8"
21 = 1/2"
26 = 3/4"
33 = 1"

ROSCA GAS

CONEXIÓN MANGUERA

3 = Para 3 mm LW (1/8")
4 = Para 4 mm LW (5/32")
6 = Para 5 mm LW (1/4")
8 = Para 8 mm LW (5/16")
9 = Para 9 mm LW (3/8")
13 = Para 13 mm LW (1/2")
19 = Para 19 mm LW (3/4")
25 = Para 25 mm LW (1")

04 = Para 3 x 4 mm
05 = Para 3 x 5 mm
36 = Para 3 x 6,3 mm
06 = Para 3 x 6 mm
46 = Para 4 x 6,3 mm
08 = Para 6 x 8 mm
10 = Para 8 x 10 mm
12 = Para 9 x 12 mm
16 = Para 13 x 16 mm

MANGUERA PLÁSTICA

X = Sin junta
P = Perbunan NBR
V = FKM/FPM
E = EPDM de etileno-propileno
K = FFKM

Añadiendo 2 codificación de color para el plástico

B = Azul
G = Verde
R = Rojo
Y = Amarillo

JUNTA

X = Sin tratamiento
N = Niquelado
C = Cromado
Z = Cincado
D = Durmicoated (chemic. zinc plated)
G = Cincado y cromado amarillo
P = Los resortes de presión hechos de PEEK (sólo para RECTUCHEM+)

COLOR

SUPERFICIE

21

KA

AW

13

M

P

X

SERIE N°

MATERIAL

M = Latón CuZn39Pb3 - 2.0401 (excepto corredera)
B = Latón CuZn39Pb3 - 2.0401 (completamente)
S = Acero 9SMnPb28K - 1.0718
R = Acero Inoxidable - AISI 303
E = Acero Inoxidable - AISI 316 L
D = POM (Delrin)
F = PVDF

AÑADIENDO 1

S = Marcado para la versión especial
0 = RECTUKey ronda
3 = RECTUKey triángulo
6 = RECTUKey hexágono
8 = RECTUKey octógono

CONEXIÓN DE LA MANGUERA

TF = Espiga acanalada
TH = Espiga acanalada 45°
TR = Espiga acanalada 90°
TP = Parker Push-Lok
PH = Parker Push-Lok 45°
PR = Parker Push-Lok 90°
TS = Con espiga acanalada
TE = Instalación del panel frontal, montaje del panel espiga acanalada

ROSCA MACHO

AW = BSP cilíndrico
AM = Rosca métrica DIN 13
AK = BSP cónico
AN = Rosca NPT ANSI B 1.20.1 cónica
AD = Rosca métrica DIN 2353 (ISO 8434-1)
AR = BSP cónico 90°

ROSCA HEMBRA

IW = BSP cilíndrico
IM = Rosca métrica DIN 13
IK = BSP cónico
IN = Rosca NPSF ANSI B 1.20.3
IT = Rosca cónica NPT ANSI B 1.20.1

CONEXIÓN DEL TUBO DE PLÁSTICO

S = Con tuerca de manguera, sin protección de resorte
KS = Montado en un panel, sin protección de resorte
KK = Con la protección de resorte



Enchufes rápidos para moldes

HIDRÁULICA



← ISO B →



ENCHUFE

MODELO LATÓN	PRESIÓN MAX. DE TRABAJO	ROSCA
71KBIW10MPX	250	1/8
72KBIW13MPX	200	1/4
73KBIW17MPX	200	3/8
74KBIW21MPX	150	1/2
75KBIW26MPX	100	3/4
76KBIW33MPX	100	1

ENCHUFE

MODELO ACERO	PRESIÓN MAX. DE TRABAJO	ROSCA
IB2510	400	1/4
IB3810	320	3/8
IB5010	300	1/2
IB7510	300	3/4
IB10010	300	1

RACOR

71SBIW10MPX	250	1/8
72SBIW13MPX	200	1/4
73SBIW17MPX	200	3/8
74SBIW21MPX	150	1/2
75SBIW26MPX	100	3/4
76SBIW33MPX	100	1

RACOR

IB2520	400	1/4
IB3820	320	3/8
IB5020	300	1/2
IB7520	300	3/4
IB10020	300	1

 En cajas de 10 ud.

HIDROLIMPIADORAS

Paso libre 12 mm - 200 BAR



ENCHUFE

MODELO LATÓN	ROSCA
EHL12H38	3/8
EHL12H12	1/2

ENCHUFE

MODELO INOX 303	ROSCA
EHL12H38X	3/8
EHL12H12X	1/2
EHL12M12X	1/2

RACOR

MODELO ACERO NIQUELADO	ROSCA
RHL12H14	1/4
RHL12H38	3/8
RHL12H12	1/2

RACOR

RHL12H14X	1/4
RHL12H38X	3/8
RHL12H12X	1/2
RHL12M12X	1/2



Enchufes rápidos para moldes

86 KF

Sin válvula.
Caudal 33 Lit.
Paso: 6 mm



86 KB

Con válvula
Caudal 15 Lit.
Paso: 6 mm



DOBLE
OBTURACIÓN



ENCHUFE: Latón
RACOR: Latón, Latón niquelado (SXN)
MUELLE: AISI 301
BOLAS: AISI 420
JUNTA: Vitón (FKM)
TEMP. DE TRABAJO:
-15° C a 200° C
COMPATIBLE CON:
SN6 de DME
09906 de RTC
6 de STS



ENCHUFE: Latón niquelado
RACOR: Latón
MUELLE: AISI 301
BOLAS: AISI 420
JUNTA: Vitón (FKM)
TEMP. DE TRABAJO:
-15° C a 200° C
COMPATIBLE CON:
SN6 de DME
09906 de RTC
6 de STS

MODELO	R
86KFIW10MVX	1/8
86KFIW13MVX	1/4

86KFTF06MVX	6
86KFTF09MVX	9

86KFTH06MVX	6
86KFTH09MVX	9

86KFTR06MVX	6
86KFTR09MVX	9

86SFAK10MXX	1/8
86SFAK13MXX	1/4
86SFAK17MXX	3/8

86SFIW10MXX	1/8
86SFIW13MXX	1/4

86SFIW13SXN	1/4
-------------	-----

86VN1010MXX	100 mm
-------------	--------



MODELO	R
86KBIW10MVX	1/8
86KBIW13MVX	1/4

86KBTF06MVX	6
86KBTF09MVX	9

86KBTH06MVX	6
86KBTH09MVX	9

86KBTR06MVX	6
86KBTR09MVX	9

86SBAK13MVX	1/4
-------------	-----



VITÓN

MODELO	D186V



Enchufes rápidos para moldes

87 KF

Sin válvula
Caudal 61 Lit.
Paso: 9 mm



87 KB

Con válvula
Caudal 29 Lit.
Paso: 9 mm



ENCHUFE: Latón
RACOR: Latón, Latón niquelado (SXN)
MUELLE: AISI 301
BOLAS: AISI 420
JUNTA: Vitón (FKM)
TEMP. DE TRABAJO:
-15° C a 200° C
COMPATIBLE CON:
SN9 de DME
9 de STS
09909 de RTC



ENCHUFE: Latón niquelado
RACOR: Latón
MUELLE: AISI 301
BOLAS: AISI 420
JUNTA: Vitón (FKM)
TEMP. DE TRABAJO:
-15° C a 200° C
COMPATIBLE CON:
SN9 de DME
9 de STS
09909 de RTC

MODELO	R
87KFIW13MVX	1/4
87KFIW17MVX	3/8

87KFAW17MVX	3/8
-------------	-----

87KFTF09MVX	9
87KFTF11MVX	11
87KFTF13MVX	13

87KFTH09MVX	9
87KFTH13MVX	13

87KFTR09MVX	9
87KFTR13MVX	13

87SFAK13MXX	1/4
87SFAK17MXX	3/8
87SFAK21MXX	1/2

87SFIW13SXN	1/4
87SFIW17SXN	3/8

87SFIW13MXX	1/4
87SFIW17MXX	3/8

87VN1310MXX	100 mm
87VN1315MXX	150 mm
87VN1325MXX	250 mm

87SFAR13MXX	1/4
-------------	-----

87SFTF13MXX	13
-------------	----



MODELO	R
87KBIW13MVX	1/4
87KBIW17MVX	3/8

87KBAW17MVX	3/8
-------------	-----

87KBTF09MVX	9
87KBTF13MVX	13

87KBTH09MVX	9
87KBTH13MVX	13

87KBTR09MVX	9
87KBTR13MVX	13

87SBAK13MVX	1/4
87SBAK17MVX	3/8



SILICONA

MOD. DI87S



VITÓN

MOD. DI87V



Enchufes rápidos

88 KF

Sin válvula
Caudal 85 Lit.
Paso: 13 mm



88 KA

Con válvula
Caudal 40 Lit.
Paso: 13 mm



ENCHUFE: Latón
RACOR: Latón
MUELLE: AISI 420
BOLAS: AISI 420
JUNTA: Vitón (FKM)
TEMP. DE TRABAJO:
-15° C a 200° C
COMPATIBLE CON:
SN16 de DME
16 de STS
09915 de RTC



ENCHUFE: Latón
RACOR: Latón
MUELLE: AISI 420
BOLAS: AISI 420
JUNTA: Vitón (FKM)
TEMP. DE TRABAJO:
-15° C a 200° C
COMPATIBLE CON:
SN16 de DME
16 de STS
09915 de RTC

MODELO	R
88KFIW21MVX	1/2



MODELO	R
88KAIW21MVX	1/2

88KFTF19MVX	19
-------------	----



88KATF19MVX	19
-------------	----

88KFTR19MVX	19
-------------	----



88KATR19MVX	19
-------------	----

88SFAK21MXX	1/2
88SFAK26MXX	3/4



88SFIW17MXX	3/8
-------------	-----



VITÓN

MODELO	
DI88V	



Enchufes rápidos

17 KA

Caudal 890 Lit.
 Paso: 5 mm
 Presión de entrada: 6 bar
 Caída de presión: 0,5 bar



ENCHUFE: Acero niquelado
 RACOR: Acero niquelado
 MUELLE: AISI 301
 BOLAS: AISI 420
 JUNTA: NBR
 COMPATIBLE CON:
 CEJN 317
 Schrader NWS
 Standard UK

18 KA

Caudal 970 Lit.
 Paso: 5,5 mm
 Presión de entrada: 6 bar
 Caída de presión: 0,5 bar



ENCHUFE: Acero niquelado
 RACOR: Acero niquelado
 MUELLE: AISI 301
 BOLAS: AISI 420
 JUNTA: NBR
 COMPATIBLE CON:
 Prevost CSI06
 CEJN 291
 Staubli RBE6

MODELO	R
17KAAK13SPN	1/4
17KAAK17SPN	3/8
17KAAK21SPN	1/2

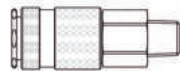

MODELO	R
18KAAK13MPN	1/4
18KAAK17MPN	3/8
18KAAK21MPN	1/2

17KAIW13SPN	1/4
17KAIW17SPN	3/8
17KAIW21SPN	1/2

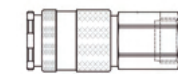

18KAIW13MPN	1/4
18KAIW17MPN	3/8
18KAIW21MPN	1/2

17KATF08SPN	8
17KATF10SPN	10
17KATF13SPN	13

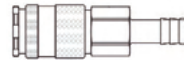
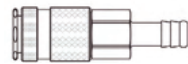

18KATF06MPN	6
18KATF08MPN	8
18KATF10MPN	10
18KATF13MPN	13

17SFAK10SXN	1/8
17SFAK13SXN	1/4

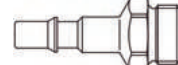

18SFAW13SXN	1/4
18SFAW17SXN	3/8

17SFIW10SXN	1/8
17SFIW13SXN	1/4

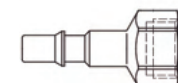
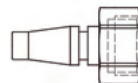

18SFIW13SXN	1/4
18SFIW17SXN	3/8

17SFTF08SXN	8
17SFTF10SXN	10



18SFTF06SXN	6
18SFTF08SXN	8
18SFTF10SXN	10



Enchufes rápidos

20 KA



SIMPLE
OBTURACIÓN

Caudal 165 Lit.
Paso: 2,7 mm
Presión de entrada: 6 bar
Caída de presión: 0,5 bar



PERFIL

20 KA INOX.



SIMPLE
OBTURACIÓN

Caudal 165 Lit.
Paso: 2,7 mm
Presión de entrada: 6 bar
Caída de presión: 0,5 bar



PERFIL



ENCHUFE: Latón
RACOR: Latón
MUELLE: AISI 301
BOLAS: AISI 420
JUNTA: NBR
COMPATIBLE CON:
Rectus 91
Walter 06-003



ENCHUFE: AISI 303
RACOR: AISI 303
MUELLE: AISI 301
BOLAS: AISI 420
JUNTA: Vitón (FKM)
COMPATIBLE CON:
Rectus 91
Walter 06-003

MODELO	R
20KAAM05MPX	M 5
20KAAW10MPX	1/8

20KAIM05MPX	M 5
20KAIW10MPX	1/8

20KATF03MPX	3
20KATF04MPX	4
20KATF05MPX	5

20KAKO04MPX	3 x 4
20KAKO05MPX	3 x 5
20KAKO06MPX	4 x 6

20KAKS04MPX	3 x 4
20KAKS05MPX	3 x 5
20KAKS06MPX	4 x 6

20KATS04MPX	4
20KATS06MPX	6

20SFAM05MXX	M 5
20SFAW10MXX	1/8

20SFIM05MXX	M 5
20SFIW10MXX	1/8

20SFKO04MXX	3 x 4
20SFKO05MXX	3 x 5
20SFKO06MXX	4 x 6

20SFTF03MXX	3
20SFTF04MXX	4

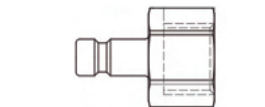
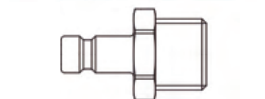
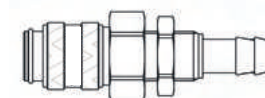
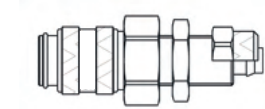
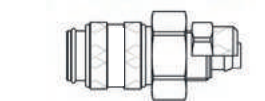
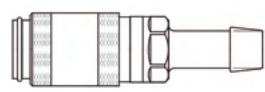
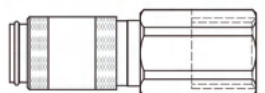
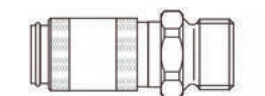

MODELO	R
20KAAM05RVX	M 5
20KAAW10RVX	1/8

20KAIM05RVX	M 5
20KAIW10RVX	1/8

20KATF04RVX	4
20KATF05RVX	5

20KAKO04RVX	3 x 4
20KAKO05RVX	3 x 5
20KAKO06RVX	4 x 6

20KAKS04RVX	3 x 4
20KAKS05RVX	3 x 5
20KAKS06RVX	4 x 6

20SFAM05RXX	M 5
20SFAW10RXX	1/8

20SFIM05RXX	M 5
20SFIW10RXX	1/8

20SFKO04RXX	3 x 4
20SFKO05RXX	3 x 5
20SFKO06RXX	4 x 6

20SFTF03RXX	3
20SFTF04RXX	4
20SFTF05RXX	5



Enchufes rápidos

21 KA

Caudal 550 Lit.
Paso: 5 mm
Presión de entrada: 6 bar
Caída de presión: 0,5 bar



SIMPLE
OBTURACIÓN



ENCHUFE: Latón
RACOR: Latón
MUELLE: AISI 301
BOLAS: AISI 420
JUNTA: NBR
COMPATIBLE CON:
Rectus 90
Norgrem 233
Camozzi 505

MODELO	R
21KAAW10MPX	1/8
21KAAW13MPX	1/4
21KAAW17MPX	3/8

21KAIW10MPX	1/8
21KAIW13MPX	1/4
21KAIW17MPX	3/8

21KATF04MPX	4
21KATF05MPX	5
21KATF06MPX	6
21KATF08MPX	8
21KATF10MPX	10

21KAKO06MPX	4 x 6
21KAKO08MPX	6 x 8

21KAKS06MPX	4 x 6
21KAKS08MPX	6 x 8

21KATS04MPX	4
21KATS06MPX	6
21KATS08MPX	8
21KATS10MPX	10

21SFAW10MXX	1/8
21SFAW13MXX	1/4
21SFAW17MXX	3/8

21SFIW10MXX	1/8
21SFIW13MXX	1/4
21SFIW17MXX	3/8

21SFKO06MXX	4x6
21SFKO08MXX	6x8
21SFKO10MXX	8x10

21SFTF04MXX	4
21SFTF05MXX	5
21SFTF06MXX	6
21SFTF08MXX	8
21SFTF10MXX	10



PERFIL

21 KA INOX.

Caudal 560 Lit.
Paso: 5 mm
Presión de entrada: 6 bar
Caída de presión: 0,5 bar



SIMPLE
OBTURACIÓN



ENCHUFE: AISI 303
RACOR: AISI 303
MUELLE: AISI 301
BOLAS: AISI 420
JUNTA: Vitón (FKM)
COMPATIBLE CON:
Rectus 90
Norgrem 233
Camozzi 505

MODELO	R
21KAAW10RVX	1/8
21KAAW13RVX	1/4
21KAAW17RVX	3/8

21KAIW10RVX	1/8
21KAIW13RVX	1/4
21KAIW17RVX	3/8

21KATF04RVX	4
21KATF06RVX	6
21KATF08RVX	8
21KATF10RVX	10

21KAKO06RVX	4 x 6
21KAKO08RVX	6 x 8

21KAKS06RVX	4 x 6
21KAKS08RVX	6 x 8

21KATS06RVX	6
21KATS08RVX	8

21SFAW10RXX	1/8
21SFAW13RXX	1/4
21SFAW17RXX	3/8

21SFIW10RXX	1/8
21SFIW13RXX	1/4
21SFIW17RXX	3/8

21SFKO06RXX	4 x 6
21SFKO08RXX	6 x 8

21SFTF04RXX	4
21SFTF06RXX	6
21SFTF08RXX	8
21SFTF10RXX	10

► Consultar KB (doble obturación).





Enchufes rápidos

21 KA HEXAG.

Caudal 550 Lit.
Paso: 5 mm
Presión de entrada: 6 bar
Caída de presión: 0,5 bar



SIMPLE
OBTURACIÓN



ENCHUFE: Latón
RACOR: Latón
MUELLE: AISI 301
BOLAS: AISI 420
JUNTA: NBR



HEXAGONAL

21 KA OCTOG.

Caudal 550 Lit.
Paso: 5 mm
Presión de entrada: 6 bar
Caída de presión: 0,5 bar



SIMPLE
OBTURACIÓN



ENCHUFE: Latón
RACOR: Latón
MUELLE: AISI 301
BOLAS: AISI 420
JUNTA: NBR



OCTOGONAL

MODELO	R
21KAAW10MPX6	1/8
21KAAW13MPX6	1/4

21KAIW10MPX6	1/8
21KAIW13MPX6	1/4

21KATF04MPX6	4
21KATF06MPX6	6
21KATF08MPX6	8

21KAKO06MPX6	4 x 6
--------------	-------

21KATS04MPX6	4
21KATS06MPX6	6

21SFAW10MXX6	1/8
21SFAW13MXX6	1/4

21SFIW10MXX6	1/8
21SFIW13MXX6	1/4

21SFTF04MXX6	4
21SFTF06MXX6	6

21SFKO06MXX6	4 x 6
21SFKO08MXX6	6 x 8

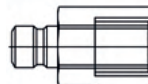
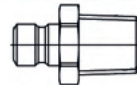
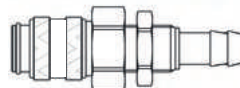
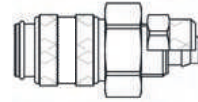
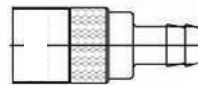
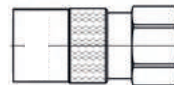
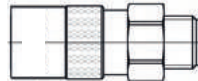

MODELO	R
21KAAW10MPX8	1/8
21KAAW13MPX8	1/4

21KAIW10MPX8	1/8
21KAIW13MPX8	1/4

21KATF04MPX8	4
21KATF06MPX8	6
21KATF08MPX8	8

21KAKO06MPX8	4 x 6
21KAKO08MPX8	6 x 8

21KATS04MPX8	4
21KATS06MPX8	6

21SFAW10MXX8	1/8
21SFAW13MXX8	1/4

21SFIW10MXX8	1/8
21SFIW13MXX8	1/4

21SFTF04MXX8	4
21SFTF06MXX8	6

21SFKO06MXX8	4 x 6
21SFKO08MXX8	6 x 8



Enchufes rápidos

21 KA TRIANG.



SIMPLE
OBTURACIÓN

Caudal 550 Lit.
Paso: 5 mm
Presión de entrada: 6 bar
Caída de presión: 0,5 bar



PERFIL

21 KA RED.



SIMPLE
OBTURACIÓN

Caudal 550 Lit.
Paso: 5 mm
Presión de entrada: 6 bar
Caída de presión: 0,5 bar



PERFIL



ENCHUFE: Latón
RACOR: Latón
MUELLE: AISI 301
BOLAS: AISI 420
JUNTA: NBR



TRIANGULAR



ENCHUFE: Latón
RACOR: Latón
MUELLE: AISI 301
BOLAS: AISI 420
JUNTA: NBR



REDONDO

MODELO	R
21KAAW10MPX3	1/8
21KAAW13MPX3	1/4

21KAIW10MPX3	1/8
21KAIW13MPX3	1/4

21KATF04MPX3	4
21KATF06MPX3	6
21KATF08MPX3	8

21KAKO06MPX3	4 x 6
21KAKO08MPX3	6 x 8

21KATS04MPX3	4
21KATS06MPX3	6
21KATS08MPX3	8

21SFAW10MXX3	1/8
21SFAW13MXX3	1/4

21SFIW10MXX3	1/8
21SFIW13MXX3	1/4

21SFTF04MXX3	4
21SFTF06MXX3	6

21SFKO06MXX3	4 x 6
21SFKO08MXX3	6 x 8

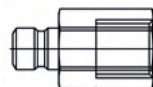
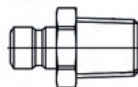
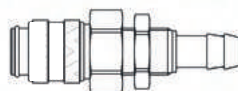
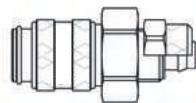
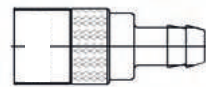
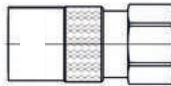
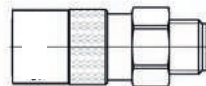

MODELO	R
21KAAW10MPX0	1/8
21KAAW13MPX0	1/4

21KAIW10MPX0	1/8
21KAIW13MPX0	1/4

21KATF04MPX0	4
21KATF06MPX0	6
21KATF08MPX0	8

21KAKO06MPX0	4 x 6
21KAKO08MPX0	6 x 8

21KATS04MPX0	4
21KATS06MPX0	6
21KATS08MPX0	8

21SFAW10MXX0	1/8
21SFAW13MXX0	1/4

21SFIW10MXX0	1/8
21SFIW13MXX0	1/4

21SFTF04MXX0	4
21SFTF06MXX0	6

21SFKO06MXX0	4 x 6
21SFKO08MXX0	6 x 8



Enchufes rápidos

24 KA

Caudal 550 Lit.
Paso: 5,5 mm
Presión de entrada: 6 bar
Caída de presión: 0,5 bar



24 KE

Seguridad.
Caudal 820 Lit.
Paso: 5,5 mm
Presión de entrada: 6 bar
Caída de presión: 0,5 bar



ENCHUFE: Latón
RACOR: Acero niquelado
MUELLE: AISI 301
BOLAS: AISI 420
JUNTA: NBR
COMPATIBLE CON:
Rectus 23
Rectus 1400
Rectus 1423
US.MIL.C 4109 1/4
CEJN 310
Prevost ISI06



ENCHUFE: Termoplástico
RACOR: Acero niquelado
MUELLE: AISI 301
BOLAS: AISI 420
JUNTA: NBR
COMPATIBLE CON:
Rectus 23
Rectus 1400
Rectus 1423,
US.MIL.C 4109 1/4
Prevost ISI06

MODELO	R
24KAAW13MPX	1/4
24KAAW17MPX	3/8
24KAAW21MPX	1/2

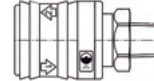
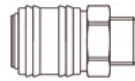

MODELO	R
24KEAK13MPN	1/4
24KEAK17MPN	3/8
24KEAK21MPN	1/2

24KAIW13MPX	1/4
24KAIW17MPX	3/8
24KAIW21MPX	1/2

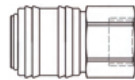

24KEIW13MPN	1/4
24KEIW17MPN	3/8
24KEIW21MPN	1/2

24KATF06MPX	6
24KATF08MPX	8
24KATF10MPX	10
24KATF13MPX	13

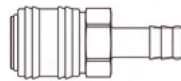

24KETF08MPN	8
24KETF10MPN	10
24KETF13MPN	13

23SFAK10SXN	1/8
23SFAK13SXN	1/4
23SFAK17SXN	3/8
23SFAK21SXN	1/2

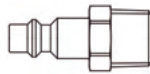

23SFAK10SXN	1/8
23SFAK13SXN	1/4
23SFAK17SXN	3/8
23SFAK21SXN	1/2

23SFIW10SXN	1/8
23SFIW13SXN	1/4
23SFIW17SXN	3/8
23SFIW21SXN	1/2

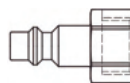

23SFIW10SXN	1/8
23SFIW13SXN	1/4
23SFIW17SXN	3/8
23SFIW21SXN	1/2

23SFTF06SXN	6
23SFTF08SXN	8
23SFTF10SXN	10
23SFTF13SXN	13



23SFTF06SXN	6
23SFTF08SXN	8
23SFTF10SXN	10
23SFTF13SXN	13



Enchufes rápidos

**A024
INOX.**

Caudal 1300 Lit.
Paso: 5,5 mm
Presión de entrada: 6 bar
Caída de presión: 0,5 bar



23 KA

Ultrafluo
Caudal 960 Lit.
Paso: 5,5 mm
Presión de entrada: 6 bar
Caída de presión: 0,5 bar



ENCHUFE: AISI 303
RACOR: AISI 303
MUELLE: AISI 302
BOLAS: AISI 316
JUNTA: FKM
COMPATIBLE CON:
Rectus 23
Rectus 1400
Rectus 1423
US.MIL.C 4109 1/4
CEJN 310



ENCHUFE: Latón niquelado
RACOR: Acero niquelado
MUELLE: AISI 301
BOLAS: AISI 420
JUNTA: NBR
COMPATIBLE CON:
Rectus 400
Rectus 1400
Rectus 1423
US.MIL.C 4109 1/4
CEJN 310
Prevost ISI06

MODELO	R
A024KAAW13X	1/4
A024KAAW17X	3/8
A024KAAW21X	1/2

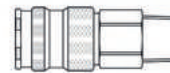
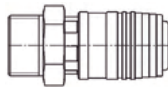

MODELO	R
23KAAK13MPN	1/4
23KAAK17MPN	3/8
23KAAK21MPN	1/2

A024KAIW13X	1/4
A024KAIW17X	3/8
A024KAIW21X	1/2

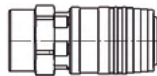

23KAIW13MPN	1/4
23KAIW17MPN	3/8
23KAIW21MPN	1/2

A024KATF08X	8
A024KATF10X	10
A024KATF13X	13

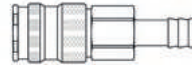
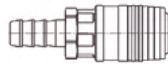

23KATF08MPN	8
23KATF10MPN	10
23KATF13MPN	13

A023SFAK13X	1/4
A023SFAK17X	3/8
A023SFAK21X	1/2

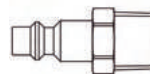
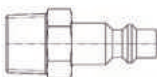

23SFAK10SXN	1/8
23SFAK13SXN	1/4
23SFAK17SXN	3/8
23SFAK21SXN	1/2

A023SFIW13X	1/4
A023SFIW17X	3/8
A023SFIW21X	1/2

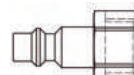
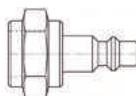

23SFIW10SXN	1/8
23SFIW13SXN	1/4
23SFIW17SXN	3/8
23SFIW21SXN	1/2

A023SFTF08X	8
A023SFTF10X	10
A023SFTF13X	13



23SFTF06SXN	6
23SFTF08SXN	8
23SFTF10SXN	10
23SFTF13SXN	13



Enchufes rápidos

26 KA

Caudal 1.070 Lit.
Paso: 7,2 mm
Presión de entrada: 6 bar
Caída de presión: 0,5 bar



ENCHUFE: Latón
RACOR: Latón
MUELLE: AISI 301
BOLAS: AISI 420
JUNTA: NBR
COMPATIBLE CON:
Rectus 25
Rectus 1600
Rectus 1625
Tema 1600
CEJN 320
Prevost ESI07

MODELO	R
26KAAW13MPX	1/4
26KAAW17MPX	3/8
26KAAW21MPX	1/2

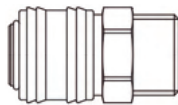

26KAIW13MPX	1/4
26KAIW17MPX	3/8
26KAIW21MPX	1/2



26KATF06MPX	6
26KATF08MPX	8
26KATF10MPX	10
26KATF13MPX	13

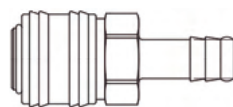

26SFAW13MXX	1/4
26SFAW17MXX	3/8
26SFAW21MXX	1/2

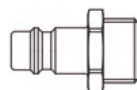

26SFIW13MXX	1/4
26SFIW17MXX	3/8
26SFIW21MXX	1/2

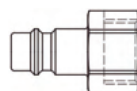

26SFTF06MXX	6
26SFTF08MXX	8
26SFTF10MXX	10
26SFTF13MXX	13

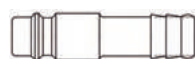

► Consultar KB (doble obturación). 



Enchufes rápidos

✓ Bajo pedido

A028

Seguridad
Caudal 1.800 Lit.
Paso: 7,8 mm
Presión de entrada: 6 bar
Caída de presión: 0,5 bar



26 KE

Seguridad
Caudal 1.070 Lit.
Paso: 7,8 mm
Presión de entrada: 6 bar
Caída de presión: 0,5 bar



ENCHUFE: Polímero reforzado
RACOR: Acero zincado
MUELLE: Acero Inox
BOLAS: Acero Inox
JUNTA: NBR
COMPATIBLE CON:
Rectus 26
Rectus 1600
Rectus 1625
Tema 1600
CEJN 320
Prevost ESI07



ENCHUFE: Termoplástico
RACOR: Acero zincado
MUELLE: AISI 301
BOLAS: AISI 420
JUNTA: NBR
COMPATIBLE CON:
Rectus 25
Rectus 1600
Rectus 1625
Tema 1600
Prevost ESI07

MODELO	R
A028KEAW13 ✓	1/4
A028KEAW17 ✓	3/8
A028KEAW21 ✓	1/2



MODELO	R
26KEAW13MPN	1/4
26KEAW17MPN	3/8
26KEAW21MPN	1/2

A028KEIW13 ✓	1/4
A028KEIW17 ✓	3/8
A028KEIW21 ✓	1/2



26KEIW13MPN	1/4
26KEIW17MPN	3/8
26KEIW21MPN	1/2

A028KETF08 ✓	8
A028KETF10 ✓	10
A028KETF13 ✓	13



26KETF08MPN	8
26KETF10MPN	10
26KETF13MPN	13

25SFAK13SXZ	1/4
25SFAK17SXZ	3/8
25SFAK21SXZ	1/2

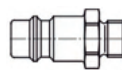

25SFAK13SXZ	1/4
25SFAK17SXZ	3/8
25SFAK21SXZ	1/2

25SFIW13SXZ	1/4
25SFIW17SXZ	3/8
25SFIW21SXZ	1/2

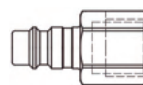

25SFIW13SXZ	1/4
25SFIW17SXZ	3/8
25SFIW21SXZ	1/2

25SFTF06SXZ	6
25SFTF08SXZ	8
25SFTF10SXZ	10
25SFTF13SXZ	13



25SFTF06SXZ	6
25SFTF08SXZ	8
25SFTF10SXZ	10
25SFTF13SXZ	13



Enchufes rápidos

25 - 1600



Ultrafluo
Caudal 1.800 Lit.
Paso: 7,8 mm
Presión de entrada: 6 bar
Caída de presión: 0,5 bar



ENCHUFE: Latón niquelado
RACOR: Acero zincado
MUELLE: AISI 301
BOLAS: AISI 420
JUNTA: NBR
COMPATIBLE CON:
Rectus 26
Rectus 1600
Rectus 1625
Tema 1600
CEJN 320
Prevost ESI 07

25 KA INOX.



Caudal 710 Lit.
Paso: 7,8 mm
Presión de entrada: 6 bar
Caída de presión: 0,5 bar



ENCHUFE: AISI 303
RACOR: AISI 303
MUELLE: AISI 301
BOLAS: AISI 316
JUNTA: Vitón (FKM)
COMPATIBLE CON:
Rectus 25
Rectus 1600
Rectus 1625
Tema 1600
CEJN 320
Prevost ESI 09

MODELO	R
1600KAAK13SPN	1/4
1600KAAK17SPN	3/8
1600KAAK21SPN	1/2



MODELO	R
25KAAW13RVX	1/4
25KAAW17RVX	3/8
25KAAW21RVX	1/2

1600KAIW13SPN	1/4
1600KAIW17SPN	3/8
1600KAIW21SPN	1/2

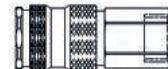
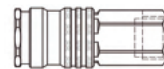

25KAIW13RVX	1/4
25KAIW17RVX	3/8
25KAIW21RVX	1/2

1600KATF08SPN	8
1600KATF10SPN	10
1600KATF13SPN	13

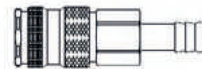
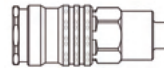

25KATF08RVX	8
25KATF10RVX	10
25KATF13RVX	13

25SFAK13SXZ	1/4
25SFAK17SXZ	3/8
25SFAK21SXZ	1/2

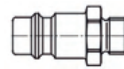

25SFAW13RXX	1/4
25SFAW17RXX	3/8
25SFAW21RXX	1/2

25SFIW13SXZ	1/4
25SFIW17SXZ	3/8
25SFIW21SXZ	1/2

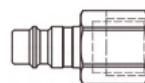

25SFIW13RXX	1/4
25SFIW17RXX	3/8
25SFIW21RXX	1/2

25SFTF06SXZ	6
25SFTF08SXZ	8
25SFTF10SXZ	10
25SFTF13SXZ	13



25SFTF08RXX	8
25SFTF10RXX	10
25SFTF13RXX	13

► Consultar KB (doble obturación). 



Enchufes rápidos

27 - 1700

Ultraflo.
Caudal 2.400 Lit.
Paso: 10 mm
Presión de entrada: 6 bar
Caída de presión: 0,5 bar



ENCHUFE: Acero niquelado
RACOR: Acero zincado
MUELLE: AISI 301
BOLAS: AISI 420
JUNTA: NBR
COMPATIBLE CON:
Rectus 27
Rectus 1700
Rectus 1727
Tema 1700
CENJ 410

MODELO	R
1700KAAK17SPN	3/8
1700KAAK21SPN	1/2
1700KAAK26SPN	3/4



1700KAIW17SPN	3/8
1700KAIW21SPN	1/2
1700KAIW26SPN	3/4



1700KATF10SPN	10
1700KATF13SPN	13
1700KATF16SPN	16
1700KATF19SPN	19



27SFAK13SXN	1/4
27SFAK17SXN	3/8
27SFAK21SXN	1/2
27SFAK26SXN	3/4

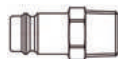

27SFIW13SXN	1/4
27SFIW17SXN	3/8
27SFIW21SXN	1/2
27SFIW26SXN	3/4



27SFTF08SXN	8
27SFTF10SXN	10
27SFTF13SXN	13
27SFTF16SXN	16
27SFTF19SXN	19



► Consultar KB (doble obturación).





Enchufes rápidos

A025



Caudal 1.200 Lit.
Paso: 5,2 mm
Presión de entrada: 6 bar
Caída de presión: 0,5 bar



PERFIL

A050



Seguridad
Caudal 1.450 Lit.
Paso: 7 mm
Presión de entrada: 6 bar
Caída de presión: 0,5 bar



PERFIL



ENCHUFE: Acero
RACOR: Acero
MUELLE: AISI 301
BOLAS: AISI 420
JUNTA: NBR



ENCHUFE: Acero
RACOR: Acero
MUELLE: AISI 301
BOLAS: AISI 420
JUNTA: NBR

MODELO	R
A025KAAW13	1/4
A025KAAW17	3/8
A025KAAW21	1/2

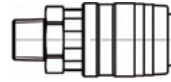
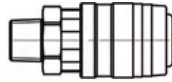

MODELO	R
A050KAAW17	3/8
A050KAAW21	1/2

A025KAIW13	1/4
A025KAIW17	3/8
A025KAIW21	1/2

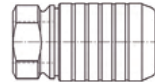
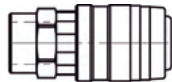

A050KAIW17	3/8
A050KAIW21	1/2

A025KATF08	8
A025KATF10	10

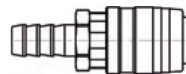
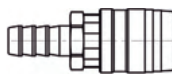

A050KATF10	10
A050KATF13	13

A025SFAK13	1/4
A025SFAK17	3/8

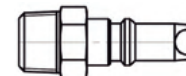
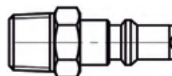

A050SFAK17	3/8
------------	-----

A025SFIW13	1/4
A025SFIW17	3/8

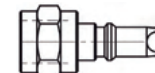
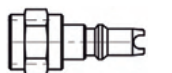

A050SFIW17	3/8
------------	-----

A025SFTF08	8
A025SFTF10	10
A025SFTF13	13

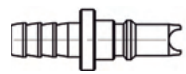

A050SFTF10	10
A050SFTF13	13



Enchufes rápidos

30KA



SIMPLE
OBTURACIÓN

Seguridad
Caudal 1.050 Lit.
Paso: 8,5 mm
Presión de entrada: 6 bar
Caída de presión: 0,5 bar



A030

Caudal 900 Lit.
Paso: 8,5 mm
Presión de entrada: 6 bar
Caída de presión: 0,5 bar



ENCHUFE: Latón
RACOR: Acero niquelado
MUELLE: AISI 301
BOLAS: AISI 420
JUNTA: NBR
COMPATIBLE CON:
US.MIL.C 4109 3/8
CEJN 430
ISO 6150B
Prevost ESI 08



ENCHUFE: Acero
RACOR: Acero niquelado
MUELLE: Inox
BOLAS: Inox
JUNTA: NBR
COMPATIBLE CON:
US.MIL.C 4109 3/8
CEJN 430
ISO 6150B/8
Prevost ESI 08

MODELO	R
30KAAW13SPX	1/4
30KAAW17SPX	3/8
30KAAW21SPX	1/2

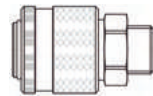

MODELO	R
A030KEAK13	1/4
A030KEAK17	3/8
A030KEAK21	1/2

30KAIW13SPX	1/4
30KAIW17SPX	3/8
30KAIW21SPX	1/2

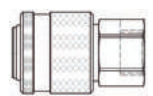

A030KEIW13	1/4
A030KEIW17	3/8
A030KEIW21	1/2

30KATF08SPX	8
30KATF10SPX	10
30KATF13SPX	13

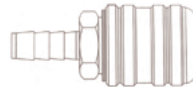
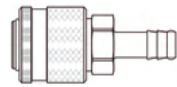

A030KETF13	13
------------	----

30SFAW13SXN	1/4
30SFAW17SXN	3/8
30SFAW21SXN	1/2

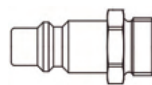

30SFAW13SXN	1/4
30SFAW17SXN	3/8
30SFAW21SXN	1/2

30SFIW13SXN	1/4
30SFIW17SXN	3/8
30SFIW21SXN	1/2

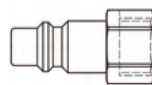

30SFIW13SXN	1/4
30SFIW17SXN	3/8
30SFIW21SXN	1/2

30SFTF08SXN	8
30SFTF10SXN	10
30SFTF13SXN	13



30SFTF08SXN	8
30SFTF10SXN	10
30SFTF13SXN	13



Enchufes rápidos

37 KA

Caudal 2.600 Lit.
Paso: 11 mm
Presión de entrada: 6 bar
Caída de presión: 0,5 bar



SIMPLE
OBTURACIÓN



ENCHUFE: Latón
RACOR: Acero niquelado
MUELLE: AISI 301
BOLAS: AISI 420
JUNTA: NBR
COMPATIBLE CON:
US.MIL.C 4109 1/2
ISO 6150B
Hansen 5000
Gromelle 1300

A037

Seguridad
Caudal 2.400 Lit.
Paso: 11 mm
Presión de entrada: 6 bar
Caída de presión: 0,5 bar



ENCHUFE: Acero
RACOR: Acero niquelado
MUELLE: Inox
BOLAS: Inox
JUNTA: NBR
COMPATIBLE CON:
US.MIL.C 4109 1/2
ISO 6150B
Hansen 5000
Gromelle 1300

MODELO	R
37KAAW17MPX	3/8
37KAAW21MPX	1/2
37KAAW26MPX	3/4



MODELO	R
A037KEAK17	3/8
A037KEAK21	1/2
A037KEAK26	3/4

37KAIW17MPX	3/8
37KAIW21MPX	1/2
37KAIW26MPX	3/4



A037KEIW17	3/8
A037KEIW21	1/2
A037KEIW26	3/4

37KATF10MPX	10
37KATF13MPX	13
37KATF16MPX	16
37KATF19MPX	19

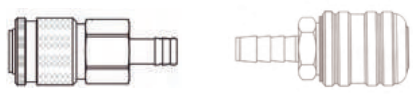

A037KETF13	13
A037KETF16	16
A037KETF19	19

37SFAN17SXN	3/8
37SFAN21SXN	1/2
37SFAK26SXN	3/4

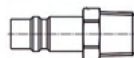

37SFAN17SXN	3/8
37SFAN21SXN	1/2
37SFAK26SXN	3/4

37SFIW21SXN	1/2
37SFIW26SXN	3/4

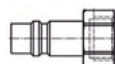

37SFIW21SXN	1/2
37SFIW26SXN	3/4

37SFTF10SXN	10
37SFTF13SXN	13
37SFTF16SXN	16
37SFTF19SXN	19



37SFTF10SXN	10
37SFTF13SXN	13
37SFTF16SXN	16
37SFTF19SXN	19



Enchufes rápidos

33 KA



SIMPLE
OBTURACIÓN

Ultraflo.
Caudal 1.700 Lit.
Paso: 8 mm
Presión de entrada: 6 bar
Caída de presión: 0,5 bar



PERFIL



ENCHUFE: Acero niquelado
RACOR: Acero niquelado
MUELLE: AISI 301
BOLAS: AISI 420
JUNTA: NBR
COMPATIBLE CON:
Atlas Copco QIC10

MODELO	R
33KAAK13SPN	1/4
33KAAK17SPN	3/8
33KAAK21SPN	1/2

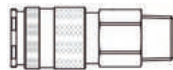

33KAIW13SPN	1/4
33KAIW17SPN	3/8
33KAIW21SPN	1/2



33KATF08SPN	8
33KATF10SPN	10
33KATF13SPN	13

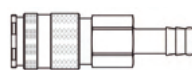

33SFAK10SXN	1/8
33SFAK13SXN	1/4
33SFAK17SXN	3/8
33SFAK21SXN	1/2

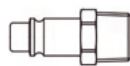

33SFIW10SXN	1/8
33SFIW13SXN	1/4
33SFIW17SXN	3/8
33SFIW21SXN	1/2

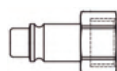

33SFTF08SXN	8
33SFTF10SXN	10
33SFTF13SXN	13



34 KA



SIMPLE
OBTURACIÓN

Ultraflo
Caudal 2.550 Lit.
Paso: 10 mm
Presión de entrada: 6 bar
Caída de presión: 0,5 bar



PERFIL



ENCHUFE: Acero niquelado
RACOR: Acero niquelado
MUELLE: AISI 301
BOLAS: AISI 420
JUNTA: NBR
COMPATIBLE CON:
Atlas Copco QIC15

MODELO	R
34KAAK13SPN	1/4
34KAAK17SPN	3/8
34KAAK21SPN	1/2
34KAAK26SPN	3/4

34KAIW13SPN	1/4
34KAIW17SPN	3/8
34KAIW21SPN	1/2
34KAIW26SPN	3/4

34KATF10SPN	10
34KATF13SPN	13
34KATF16SPN	16
34KATF19SPN	19

34SFAK13SXN	1/4
34SFAK17SXN	3/8
34SFAK21SXN	1/2

34SFIW13SXN	1/4
34SFIW17SXN	3/8
34SFIW21SXN	1/2

34SFTF06SXN	6
34SFTF10SXN	10
34SFTF13SXN	13
34SFTF16SXN	16



Enchufes rápidos

1300 KA

Ultrafluo
Caudal 1.000 Lit.
Paso: 6 mm
Presión de entrada: 6 bar
Caída de presión: 0,5 bar



1800 KA

Ultrafluo
Caudal 2.300 Lit.
Paso: 10 mm
Presión de entrada: 6 bar
Caída de presión: 0,5 bar



ENCHUFE: Latón niquelado
RACOR: Acero zincado
MUELLE: AISI 301
BOLAS: AISI 420
JUNTA: NBR
COMPATIBLE CON:
Tema 1300
Rectus 31
CEJN 303



ENCHUFE: Latón niquelado
RACOR: Acero zincado
MUELLE: AISI 301
BOLAS: AISI 420
JUNTA: NBR
COMPATIBLE CON:
Tema 1800
Rectus 32
CEJN 408

MODELO	R
1300KAAK13MPN	1/4
1300KAAK17MPN	3/8
1300KAAK21MPN	1/2

1300KAIW13MPN	1/4
1300KAIW17MPN	3/8

1300KATF08MPN	8
1300KATF10MPN	10
1300KATF13MPN	13

1300SFAK13SXZ	1/4
1300SFAK17SXZ	3/8

1300SFIW13SXZ	1/4
1300SFIW17SXZ	3/8

1300SFTF08SXZ	8
1300SFTF10SXZ	10
1300SFTF12SXZ	12

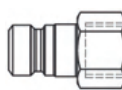
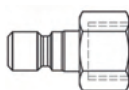
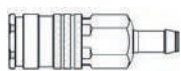

MODELO	R
1800KAAK17MPN	3/8
1800KAAK21MPN	1/2
1800KAAK26MPN	3/4

1800KAIW17MPN	3/8
1800KAIW21MPN	1/2
1800KAIW26MPN	3/4

1800KATF10MPN	10
1800KATF13MPN	13
1800KATF16MPN	16
1800KATF19MPN	19

1800SFAK13SXZ	1/4
1800SFAK17SXZ	3/8
1800SFAK21SXZ	1/2
1800SFAK26SXZ	3/4

1800SFIW13SXZ	1/4
1800SFIW17SXZ	3/8
1800SFIW21SXZ	1/2

1800SFTF08SXZ	8
1800SFTF10SXZ	10
1800SFTF12SXZ	12
1800SFTF16SXZ	16
1800SFTF19SXZ	19



Enchufes rápidos a botón

24 KP

Seguridad.
Caudal 675 Lit.
Paso: 5,5 mm.
Presión de entrada: 6 bar
Caída de presión: 0,5 bar



26 KP

Seguridad
Caudal 1.225 Lit.
Paso: 7,4 mm
Perfil Europeo
Presión de entrada: 6 bar
Caída de presión: 0,5 bar



ENCHUFE: Acero niquelado
RACOR: Acero niquelado
MUELLE: AISI 301
BOLAS: AISI 420
JUNTA: NBR
COMPATIBLE CON:
Rectus 23, 24
Rectus 1400
Rectus 1423
US.MIL.C 4109 1/4
CEJN 310
Prevost ISI06



ENCHUFE: Acero niquelado
RACOR: Acero zincado
MUELLE: AISI 301
BOLAS: AISI 420
JUNTA: NBR
COMPATIBLE CON:
Rectus 26
Rectus 1600
Rectus 1625
Tema 1600
CENJ 320
Prevost ESI07

MODELO	R
24KPAW13APX	1/4
24KPAW17APX	3/8
24KPAW21APX	1/2

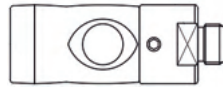

MODELO	R
26KPAW13APX	1/4
26KPAW17APX	3/8
26KPAW21APX	1/2

24KPIW13APX	1/4
24KPIW17APX	3/8
24KPIW21APX	1/2



26KPIW13APX	1/4
26KPIW17APX	3/8
26KPIW21APX	1/2

24KPTF06APX	6
24KPTF08APX	8
24KPTF10APX	10



26KPTF06APX	6
26KPTF08APX	8
26KPTF10APX	10

23SFAK10SXN	1/8
23SFAK13SXN	1/4
23SFAK17SXN	3/8
23SFAK21SXN	1/2



25SFAK13SXZ	1/4
25SFAK17SXZ	3/8
25SFAK21SXZ	1/2

23SFIW10SXN	1/8
23SFIW13SXN	1/4
23SFIW17SXN	3/8
23SFIW21SXN	1/2



25SFIW13SXZ	1/4
25SFIW17SXZ	3/8
25SFIW21SXZ	1/2

23SFTF06SXN	6
23SFTF08SXN	8
23SFTF10SXN	10
23SFTF13SXN	13



25SFTF06SXZ	6
25SFTF08SXZ	8
25SFTF10SXZ	10
25SFTF13SXZ	13



Enchufes rápidos a botón

30KP

Seguridad
Caudal 1.470 Lit.
Paso: 8 mm
Presión de entrada: 6 bar
Caída de presión: 0,5 bar

ISO 6150 B-15

ENCHUFE: Acero niquelado

RACOR: Acero niquelado

MUELLE: AISI 301

BOLAS: AISI 420

JUNTA: NBR

COMPATIBLE CON:

Rectus 30

Prevost ESI 08

IRM 08

MODELO	R
30KPAW13APX	1/4
30KPAW17APX	3/8
30KPAW21APX	1/2

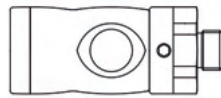

30KPIW13APX	1/4
30KPIW17APX	3/8
30KPIW21APX	1/2



30KPTF08APX	8
30KPTF10APX	10



30FAW13SXN	1/4
30FAW17SXN	3/8
30FAW21SXN	1/2

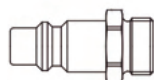

30FIW13SXN	1/4
30FIW17SXN	3/8
30FIW21SXN	1/2

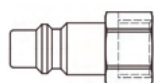

30SFTF08SXN	8
30SFTF10SXN	10
30SFTF13SXN	13





Racordaje



FIJO C/MUELLE

MODELO	R	Ø
13201	1/4	6 x 8
13202		8 x 10
13204	3/8	8 x 10



GIRATORIO C/MUELLE

MODELO	R	Ø
13211	1/4	6 x 8
13212		8 x 10
13311		5 x 8
13312		6,5 x 10
13327		8 x 12
13214	3/8	8 x 10
13215		10 x 12
13315		8 x 12
13216	1/2	12 x 15
13317		10 x 16



GIRATORIO LATÓN

MODELO	R	Ø
PV13/08	1/4	5 x 8
PV13/10		6,3 x 9,5
PV17/12	3/8	8 x 12



ESPIGA-ESPIGA

MODELO	R
13301	6
13303	8
13304	10
DS13/13	13



HEMBRA-ESPIGA

MODELO	R	Ø
GI10/08	1/8	8
13264	1/4	9
13265		10
GI13/13		13
13267	3/8	8
13268		10
30510		12
GI17/13		13
GI21/13	1/2	13



GIRATORIO

MODELO	R	Ø
13360	1/4	6
13362		8
13364		10
13369	3/8	10



LLAVE DE PASO

MODELO	R
12170	1/8
12171	1/4
12172	3/8
12173	1/2



DOBLE MACHO CILINDRICO

MODELO	R	Ø
14100	1/8	1/8
14104		1/4
14101	1/4	1/4
14107		3/8
14108		1/2
14102	3/8	3/8
14109		1/2
14103	1/2	1/2
14110		3/4
14111	3/4	3/4



MACHO-ESPIGA

MODELO	R	Ø
13231	1/8	6
13250		8
13234	1/4	6
13236		8
13253		10
GT13/13		13
13239	3/8	8
13256		10
13258		13
GT17/13		13
GT21/09	1/2	9
13242		10
13243		13
GT21/13		13
GT21/16		16
13245		17
13246		19
GT26/13		13
GT26/16		16
GT26/19		19



Racordaje



GIRATORIO

MODELO	R	Ø
13330	1/4	6
13332		8
13334		10
13337	3/8	8
13339		10
13342		13



DOBLE MACHO CÓNICO

MODELO	R	Ø
14130	1/8	1/8
14134		1/4
14135		3/8
14131	1/4	1/4
14137		3/8
14136	3/8	1/2
14132		3/8
14138		1/2
14133	1/2	1/2
14139		3/4
20006	3/4	3/4
20209		1
20007		1



ARTICULACIÓN

MODELO	R
RG 1/4	1/4
RG 3/8	3/8



ARTICULACIÓN

MODELO	R
FA13A13ISPN	1/4
FA17A17ISPN	3/8



LIMITADOR DE PRESIÓN

MODELO	R	Ø
DRV13/30	1/4	3 Bar
DRV13/40		4 Bar
DRV13/50		5 Bar
DRV13/60		6 Bar



REDUCCIÓN CILÍNDRICA

MODELO	M	H
14140	1/4	1/8
14141	3/8	1/8
14142		1/4
14144	1/2	1/4
14143		3/8
14146	3/4	3/8
14145		1/2



REDUCCIÓN CÓNICA

MODELO	M	H
14150	1/4	1/8
14151	3/8	1/8
14152		1/4
14154	1/2	1/4
14153		3/8
14155	3/4	1/2
20808	1	1/2
20809	1	3/4



TAPÓN

MODELO	R
14250	1/8
14251	1/4
14252	3/8
14253	1/2
14254	3/4



EXTENSIÓN

MODELO	M	H
14170	1/8	1/8
14171		1/4
14172		3/8
14175	1/4	1/4
14176		3/8
14180	3/8	3/8
14181		1/2
14185		1/2



DOBLE HEMBRA

MODELO	H	H
14200	1/8	1/8
14204		1/4
14205		3/8
14201	1/4	1/4
14207		3/8
14208	3/8	1/2
14202		3/8
14209		1/2
14203	1/2	1/2
30110		3/4
30006	3/4	3/4



CODO

MODELO	R
14300	1/8
14301	1/4
14302	3/8
14303	1/2
50206	3/4



Racordaje



CODO

MODELO	R
14310	1/8
14311	1/4
14312	3/8
14313	1/2
50106	3/4



DISTRIBUIDOR T

MODELO	R
14355	1/8
14356	1/4
14357	3/8
14358	1/2



DISTRIBUIDOR

MODELO	R
14320	1/8
14321	1/4
14322	3/8
14323	1/2



CODO

MODELO	R	
14315	1/8	M5
14316	1/4	G 1/8
14317	3/8	G 1/4
14318	1/2	M5



DISTRIBUIDOR T

MODELO	R
14360	1/8
14361	1/4
14362	3/8
14363	1/2



DISTRIBUIDOR

MODELO	R
14330	1/8
14331	1/4
14332	3/8
14333	1/2



DISTRIBUIDOR T

MODELO	R
14340	1/8
14341	1/4
14342	3/8
14343	1/2



DISTRIBUIDOR CRUCETA

MODELO	R
14370	1/8
14371	1/4
14372	3/8
14373	1/2



DISTRIBUIDOR

MODELO	R
Z017	3/8
Z021	1/2



DISTRIBUIDOR T

MODELO	R
14350	1/8
14351	1/4
14352	3/8
14353	1/2
40007	3/4



DISTRIBUIDOR CRUCETA

MODELO	R
14380	1/8
14381	1/4
14382	3/8
14383	1/2



UNIÓN PASATABIQUE

MODELO	R
30602	1/8 M16x1,5
30603	1/4 M20x1,5
30604	3/8 M26x1,5
30605	1/2 M28x1,5



Conexiones instantáneas

 Bajo pedido

Bajo pedido podemos suministrar conexiones instantáneas con junta de Vitón (FKM), acero inox. 1.4401, etc.

TEMPERATURA DE TRABAJO:

-20°C hasta +70°C
-20°C hasta +80°C

Junta de PVC
Junta NBR

PRESIÓN DE TRABAJO:

Hasta 16 bar

Dependiendo del rango de presión y el tubo utilizado.

VACÍO: Max. 98%

MATERIAL:

Cuerpo en latón niquelado
Junta NBR
Pinza sujeción acero inox 1.4401
Anillo de empuje de plástico negro

ROSCA:

Cilíndrico, DIN EN ISO 228
Cónico, DIN EN 10226 (DIN2999)
Métrico, DIN ISO 261

Cilíndrica con junta tórica

FLUIDOS:

Aire comprimido, lubricado y sin lubricar.

TUBOS:

Para tubos lineales con ISO 14743
Tolerancia para diam. Ext. 4 a 8: +-0,1
Tolerancia para diam. Ext. 10 a 14: +-0,15 (PU)
- 10 a 14: +-0,1 (PA)

Materiales recomendados PU, PA



IP 01



Racor recto cilíndrico con junta tórica

MODELO	Ø	R
200101	4	M5
200102	4	G 1/8
200103	4	G 1/4
200104	5	M5
200105	5	G 1/8
200106	5	G 1/4
200100	6	M5
200107	6	G 1/8
200108	6	G 1/4
200118	6	G 3/8
200109	8	G 1/8
200110	8	G 1/4
200111	8	G 3/8
200133	8	G 1/2
200112	10	G 1/4
200113	10	G 3/8
200135	10	G 1/2
200119	12	G 1/4
200114	12	G 3/8
200115	12	G 1/2
200116	14	G 3/8
200117	14	G 1/2



IP 01K

Racor recto cónico

MODELO	Ø	R
200152 	4	R 1/8
200153 	4	R 1/4
200154	6	R 1/8
200155	6	R 1/4
200156	8	R 1/8
200157	8	R 1/4
200158	8	R 3/8
200159	10	R 1/4
200160	10	R 3/8



IP 02

Racor recto hembra

MODELO	Ø	R
200200 	4	M5
200201	4	G 1/8
200202	4	G 1/4
200203	5	G 1/8
200204	5	G 1/4

200205	6	G 1/8
200206	6	G 1/4
200207	8	G 1/8
200208	8	G 1/4
200209	10	G 1/4
200210	10	G 3/8



IP 03

Racor recto intermedio

MODELO	Ø D1	Ø D2
200300	3	3
200301	4	4
200302	5	5
200303	6	6
200304	8	8
200305	10	10
200306	12	12
200307	14	14
Reducciones		
200308	6	4
200309	8	6
200310	10	8
200311	12	10



Conexiones instantáneas

✓ Bajo pedido



IP 04

Racor codo unión 2 tubos

MODELO	Ø
200400	3
200401	4
200402	5
200403	6
200404	8
200405	10
200406	12
200407	14



IP 05

Racor T conector

MODELO	Ø D1	Ø D2
200500 ✓	3	3
200501	4	4
200502	5	5
200503	6	6
200504	8	8
200505	10	10
200506	12	12
200507	14	14
Reducciones		
200508	6	4
200509	8	6
200510	10	8



IP 022

Racor codo giratorio macho con junta tórica

MODELO	Ø	R
202200	4	M5
202201	4	G 1/8
202202	4	G 1/4
202227	5	M5
202228	5	G 1/8
202230	5	G 1/4

202215	6	M5
202225	6	M6
202218 ✓	6	M12x1,25
202203	6	G 1/8
202204	6	G 1/4
202205	8	G 1/8
202206	8	G 1/4
202207	8	G 3/8
202208	10	G 1/4
202209	10	G 3/8
202224	10	G 1/2
202210	12	G 1/4
202211	12	G 3/8
202212	12	G 1/2
202213	14	G 3/8
202214	14	G 1/2



IP 022 KEGL

Racor codo giratorio macho cónico

MODELO	Ø	R
202251 ✓	4	R 1/8
202252 ✓	4	R 1/4
202253	6	R 1/8
202254 ✓	6	R 1/4
202255 ✓	8	R 1/8
202256 ✓	8	R 1/4
202257	8	R 3/8
202258 ✓	10	R 1/4
202259 ✓	10	R 3/8
202260	12	R 3/8
202261 ✓	12	R 1/2



IP 025

Racor hembra intermedio pasamuros

MODELO	Ø	R	M
202502	4	G 1/8	M10X1
202504	6	G 1/8	M14X1
202505	6	G 1/4	M14X1
202506	8	G 1/8	M16X1
202507	8	G 1/4	M16X1



IP 024

Racor y macho tecnopolímero con junta tórica

MODELO	Ø	R
202400 ✓	4	M5
202401 ✓	4	G 1/8
202402 ✓	4	G 1/4
202403 ✓	6	G 1/8
202404	6	G 1/4
202405	8	G 1/8
202406	8	G 1/4
202407	8	G 3/8



IP 010

Racor recto intermedio pasamuros

MODELO	Ø	M
201101	4	M10X1
201102	5	M11X1
201103	6	M14X1
201104	8	M16X1
201105	10	M17X1
201106 ✓	12	M20X1
201107	14	M22X1



IP 020

Racor T giratorio macho con junta

MODELO	Ø	R
202000 ✓	4	M5
202001	4	G 1/8
202002 ✓	4	G 1/4
202003	6	G 1/8
202004	6	G 1/4
202005	8	G 1/8
202006	8	G 1/4
202007	8	G 3/8
202008	10	G 1/4
202009	10	G 3/8
202010 ✓	12	G 1/4
202011 ✓	12	G 3/8
202012	14	G 1/2



Conexiones instantneas

✓ Bajo pedido



IP 06

Racor adaptador macho con junta tórica

MODELO	Ø	R
200602	4	G 1/8
200603 ✓	4	G 1/4
200604 ✓	5	M5
200605 ✓	5	G 1/8
200606 ✓	5	G 1/4
200600	6	M5
200607	6	G 1/8
200608 ✓	6	G 1/4
200609 ✓	8	G 1/8
200610	8	G 1/4
200611 ✓	8	G 3/8
200618 ✓	10	G 1/8
200612	10	G 1/4
200613 ✓	10	G 3/8
200620 ✓	12	G 1/4



IP 09

Tapón

MODELO	Ø
201001	4
201002 ✓	5
201003	6
201004	8
201005	10
201006	12
201007 ✓	14



IP 08

Racor reductor

MODELO	Ø D1	Ø D2
200801 ✓	5	4
200802	6	4
200803 ✓	6	5
200804	8	4
200806	8	6
200807	10	6
200808	10	8
200809	12	4
200810	12	6
200811	12	8
200817	12	10



IP 021

Racor banjo simple giratorio con junta tórica

MODELO	Ø	R
202100 ✓	4	M5
202101 ✓	4	G 1/8
202102 ✓	4	G 1/4
202103 ✓	6	G 1/8
202104	6	G 1/4
202105 ✓	8	G 1/8
202106	8	G 1/4
202107 ✓	8	G 3/8
202108	10	G 1/4
202109 ✓	10	G 3/8
202110 ✓	12	G 1/4
202111 ✓	12	G 3/8
202112	14	G 1/2



IP 026

Racor codo giratorio macho con junta

MODELO	Ø	R
202600 ✓	4	M5
202601	4	G 1/8
202602	4	G 1/4
202615 ✓	6	M5
202603	6	G 1/8
202604	6	G 1/4
202605 ✓	8	G 1/8
202606	8	G 1/4
202607 ✓	8	G 3/8
202608 ✓	10	G 1/4
202609 ✓	10	G 3/8



IP 07

Racor doble conector

MODELO	Ø
200701	4
200702	5
200703	6
200704	8
200705	10
200706	12
200707	14



IP 023

Racor y tecnopolímero

MODELO	Ø D1	Ø D2
202301	4	4
202303	6	6
202304	8	8
202305	10	10
202306	12	12
Reducciones		
202307 ✓	6	4
202308 ✓	8	6
202309 ✓	10	8



IP 047

Racor codo unión

MODELO	Ø D1	Ø D2
204701 ✓	4	4
204703	6	6
204704	8	8
204705 ✓	10	10
204706	12	12
Reducciones		
204707 ✓	4	6
204708	6	8



IP 020-F

Racor T giratorio hembra

MODELO	Ø	R
202901	4	G 1/8
202902 ✓	4	G 1/4
202903 ✓	6	G 1/8
202904 ✓	6	G 1/4
202905 ✓	8	G 1/8
202906 ✓	8	G 1/4

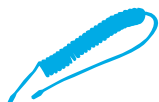

Tubo de poliuretano

DATOS TÉCNICOS

TEMPERATURA C°:
de -40°C + 60°C

DUREZA:
SHORE D 49-55(ISO 53505)

TOLERANCIA:
+- 0,07 sobre espesor de pared,
+-0,07 sobre diam. Int., +-0,07 sobre
diam. Ext., +-0,05% sobre el peso

**TABLA DE PRESIONES % EN FUNCIÓN
DE TEMPERATURA:**
20°C 100%, 30°C 83%, 40°C 72%,
50°C 64%, 60°C 47%

COLOR
Azul, resto de colores consultar.



TUBO POLIURETANO 98



MODELO	Ø	LONGITUD
PU-25	4x2,5	100
PU-40	6x4	
PU-60	8x6	
PU-80	10x8	
PU-100	12x9	
PU-120	14x10	

MODELO	Ø	LONGITUD
PUC-25	4x2,5	50
PUC-40	6x4	25
PUC-60	8x6	
PUC-80	10x8	
PUC-100	12x9	



Tubo, mangueras y espirales

RILSAN PA12

Poliamida



MODELO	Ø	L.TOT	PRES
PAL-25/25	4 x 2,7	25	28
PAL-40/25	6 x 4		
PAL-60/25	8 x 6		
PAL-80/25	10 x 8		
PAL-10/25	12 x 10		
PAL-25	4 x 2,7	100	28
PAL-30	5 x 3		
PAL-40	6 x 4		
PAL-60	8 x 6		
PAL-80	10 x 8		
PAL-10	12 x 10		

RILSAN PA11

Poliamida

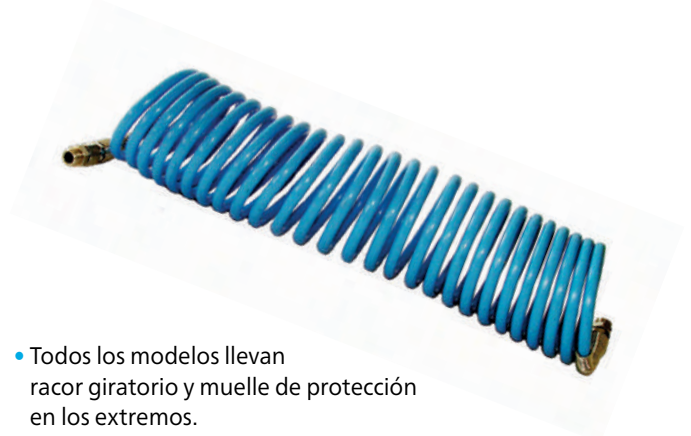

- Todos los modelos llevan racor giratorio y muelle de protección en los extremos.

MODELO	Ø	R	L.TOT	L.UTIL	PRES
20009	6 x 8	No	30	-	20
20009-5		1/4	5	3,6	
20009-7,5			7,5	5,4	
20009-10			10	7,2	
20009-15			15	10,8	
20014	8 x 10	No	30	-	
20014-5		1/4	5	3,6	
20014-7,5			7,5	5,4	
20014-10			10	7,2	
20014-15			15	10,8	

SN

Termocaucho de alta calidad con refuerzo textil, resistentes al rozamiento, resistente a productos químicos poco agresivos.



MODELO	Ø	L.TOT	TIPO	PRES
SN-0813	8x13	50	Termocaucho	20
SN-1016	10x16			
SN-1319	13x19			

PU-0812

Poliuretano Ultra flexible



MODELO	Ø	L.TOT	TIPO	PRES
PU-0812	8 x 12	50 m	Poliuretano Ultra flexible	15

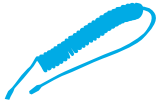

Mangueras y espirales poliuretano

SN-TO08

En caucho EPDM antiestático de alta calidad con acabado bandelado y refuerzo textil de alta tenacidad.



- Se facturarán los metros enviados.

MODELO	Ø	L.TOT	PRES
SN-TO08	8	50 m. aprox.	20

CALIDAD STANDAR

Espirales en poliuretano. Todos los modelos llevan racor giratorio y muelle de protección en los extremos.



MODELO	Ø	R	L.TOT	L.UTIL	PRES
PU08-025AZ	5x8	1/4	2,5	2	8
PU08-050AZ			5	4	
PU08-075AZ			7,5	6,2	
PU10-025AZ	6,3x9,5		2,5	2	
PU10-050AZ			5	4	
PU10-100AZ			10	8	
PU12-025AZ	8x12	3/8	2,5	2	
PU12-050AZ			5	4	
PU12-100AZ			10	8	

CALIDAD STANDAR

Espirales en poliuretano. Todos los modelos llevan racor giratorio y muelle de protección en los extremos.

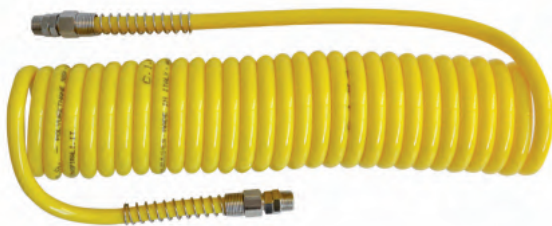

MODELO	Ø	R	L.TOT	L.UTIL	PRES
TPU08-03AM	5x8	1/4	3	2,4	8
TPU08-06AM			6	4,8	
TPU08-09AM			9	7,2	
TPU10-06AM	6,3x9,5		6	4,9	
TPU10-09AM			9	7,2	
TPU10-15AM			15	12	
TPU12-06AM	8x12	3/8	6	4,9	
TPU12-09AM			9	7,2	
TPU12-15AM			15	12	

NYCOIL GRAN CALIDAD

Poliuretano de alta calidad procedente del líder mundial en conducción de fluidos e instalaciones neumáticas. Excelentes características contra la abrasión y con un grado de maleabilidad alto.



MODELO	Ø	R	L.TOT	L.UTIL	PRES	
PU10-030DV05	6,3x9,5	1/4	3	2,5	8	
PU10-060DV05			6	5		
PU12-060DV05	8x12		3/8	6		5
PU12-075DV05				7,5		6,2
PU12-090DV05				9		7,4
PU15-060DV05	9,5x15			3/8		6
PU15-090DV05		9			7,4	



Enrolladores neumáticos

HR-0808 HR-1009 HR-1015A HR-1312

Cerrado plástico

- Carcasa exterior en plástico reforzado con sistema de bloqueo de manguera. Equipados con soporte giratorio de pared.

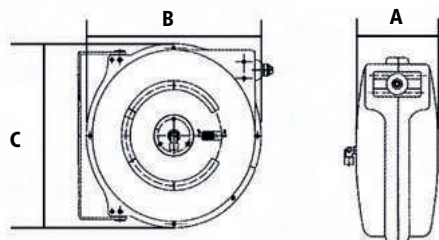

MODELO	USO	Ø MAN	LONG MANG.	PRESIÓN	R	A	B	C	KG
HR-0808	Aire y Agua	8x13 mm	8 m	20	1/4	161	346	311	5,5
HR-1009		10x16 mm	9 m	20	3/8	180	350	325	6,0
HR-1015A		10x16 mm	15 m	20	3/8	220	445	400	11,0
HR-1312		13x20 mm	12 m	20	1/2	220	445	400	11,0

HRP-1015N

- Cuerpo de acero y carrete para la manguera en material composite de calidad, equipados con guía de manguera con rodillos y sistema de bloqueo interno.
- Abierto ligero
- Carrete de plástico resistente
- -26° a 65°C

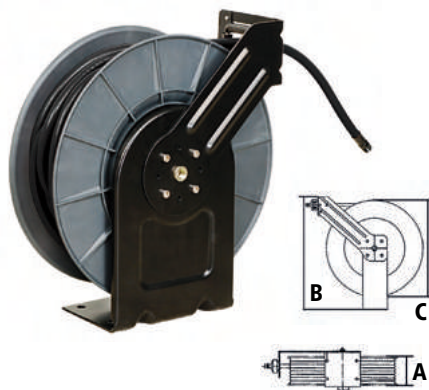

HRM-1010

- Abierto metálico
- -20° a 60°C



HRM-1020N HRM-1315N

- Abierto metálico
- -26° a 65°C



Todos los modelos con cuerpo y carrete en acero de alta calidad con tratamiento anticorrosión, equipados con guía de manguera con rodillos y sistema de bloqueo. Para la instalación de estos equipos, Aixia recomienda el uso del soporte BR0103 lo que permite su movilidad lateral.

MODELO	USO	Ø MAN	LONG MANG.	PRESIÓN	R	A	B	C	KG
HRP-1015N	Aire y agua	10x16 mm	15 m	20	3/8	130	400	360	7
HRM-1010		10x16 mm	10 m	20	3/8	155	415	355	11
HRM-1020N		10x16 mm	20 m	20	3/8	214	520	530	21
HRM-1315N		13x20 mm	15 m	20	1/2	214	520	530	24

BR0103	Soporte pared giratorio para enrolladores metálicos modelos HRM-1010, HRM-1020N, HRM-1315N
BR0101	Soporte HRP-1015N





Enrolladores eléctricos

CR-15310



CR-15315 • CR-25315



- Carcasa exterior en plástico reforzado con sistema de bloqueo de cable.
- Equipados con soporte giratorio de pared y actuador térmico de protección contra sobrecargas.

MODELO	DESCRIPCIÓN	POTENCIA	CABLE	PROTECT.	HILOS	SALIDA VOLT
CR-15310	Carcasa plástico	600/2000	10 m	IP 42	3 x 1,5	230 V
CR-15315	Carcasa plástico	1000/2000	15,5 m	IP 42	3 x 1,5	230 V
CR-25315	Carcasa plástico	1600/3200	15,5 m	IP 42	3 x 2,5	230 V



Enrolladores manuales

HRM-1030M



Longitud de la manguera: 30m

- Base giratoria 360°
- Manguera de poliuretano flexible
- Estructura de acero
- Incluye enchufe de seguridad serie 26 a botón

Todos los modelos con cuerpo y carrete en acero de alta calidad con tratamiento anticorrosión, equipados con guía de manguera con rodillos y sistema de bloqueo.

MODELO	USO	Ø	PRESIÓN	R	KG
HRM-1030M	Aire	10x13 mm	16	3/8	10



Pistolas de soplar

AB-13

MODELO	BOQUILLA	CONS. AIRE
AB-13	Boquilla corta seguridad	250 l/min

AA-13

MODELO	BOQUILLA	CONS. AIRE
AA-13	Corta	120 l/min

AN-13

MODELO	BOQUILLA	CONS. AIRE
AN-13	Corta	55 l/min

AX-13

MODELO	BOQUILLA	CONS. AIRE
AX-13	Venturi de gran caudal	211 l/min



Pistolas de soplar

AK-13 • AK-13SET



MODELO	BOQUILLA	CONS. AIRE
AK-13	100 mm	460 l/min
AK-13SET	Expositor con 10 AK-13	

AZ-13



MODELO	BOQUILLA	CONS. AIRE
AZ-13	Silen.100mm	215 l/min

5000-5



MODELO	BOQUILLA
5000-5	Flexible 80 mm

AJ13



MODELO	BOQUILLA
AJ13-300	300 mm
AJ13-500	500 mm
AJ13-1000	1000 mm



Pistolas de soplar

VR-12
AV-13

MODELO	EXTENSION
VR-12	Para AA-13

MODELO	BOQUILLA
AV-13	135mm

AS121

Pistola aire extensible:

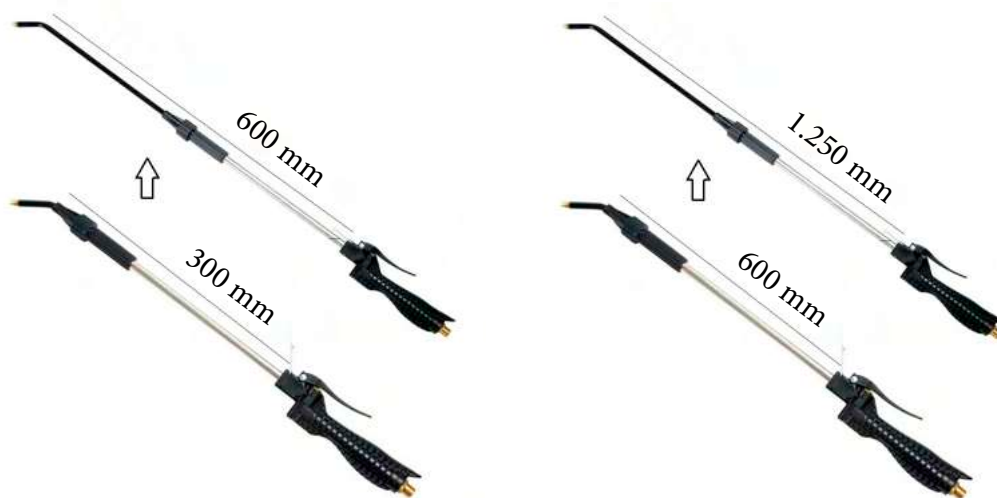

MODELO	LONGITUD
AS121-3B	300 a 600 mm
AS121-3C	600 a 1.250 mm



Pistolas de soplar, aspirar, pintar y petrolelear

AA-5005N

Puede aspirar: polvo, serrín, arena, fragmentos metálicos



- Incluye bolsa, tubo y boquillas.

MODELO	TIPO	BOQUILLAS	LONG. MAN	PESO	R
AA-5005N	Soplador - Aspirador	3 Aspirar 1 Soplar	1,3 m	0,7	1/4

SJ-111SA



MODELO	BOQUILLA	DEPÓSITO
SJ-111SA-1.5	1,5	1 L
SJ-111SA-1.8	1,8	1 L

BC-2



MODELO	LONG. BOQUILLA	DEPÓSITO
BC-2	210	1 L



Pistolas de engrasar y sellar

EN6636



MODELO	CAP.CARTUCHO	LONGITUD	PESO
EN6636	400 cc	410 mm	1,5

PSR-02

- Para aplicar silicona en cartucho de 310 ml.
- Sin válvula de descarga.



MODELO	LTUBO	CARTUCHO	PESO
PSR-02	215	310 ml	1,1

PSR-210

Con regulador de presión y válvula de descarga

- Para cartucho de silicona, masilla o poliuretano < 310 ml.



CARTUCHO	
300 ml	Ø 50-51
215 mm	
310 ml	Ø 50-51
218 mm	

MODELO	LTUBO	CARTUCHO	PESO
PSR-210	215	300-310 ml	0,75



Pistolas de sellar

PSR-270 • PSR-400

Con regulador de presión y válvula de descarga

- **PSR-270.** Para salchichón de silicona, masilla o poliuretano < 310 ml < 400 ml
- **PSR-400.** Para salchichón de silicona, masilla o poliuretano < 600 ml



SALCHICHÓN PSR-270

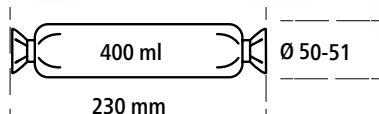
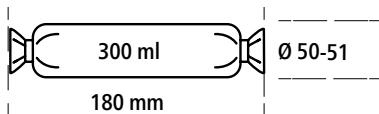

SALCHICHÓN PSR-400

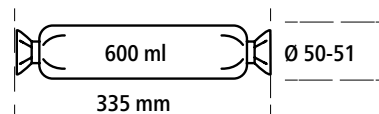
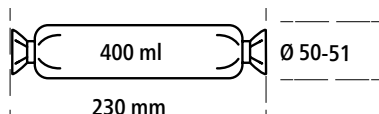
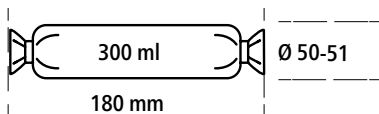

MODELO	L.TUBO	SALCHICHÓN	PESO
PSR-270	270	300-400 ml	1,0
PSR-400	400	300-400-600 ml	1,1

PSR-450

Con regulador de presión y válvula de descarga

- Admite cartucho metálico.
- Para cartucho de silicona, masilla o poliuretano < 310 ml y salchichón < 400 ml



CARTUCHO

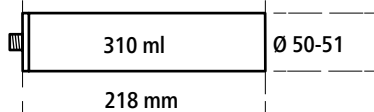
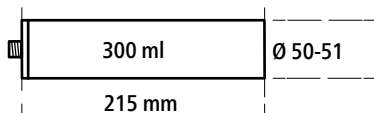

SALCHICHÓN

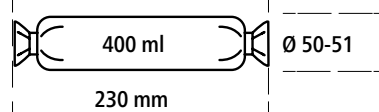
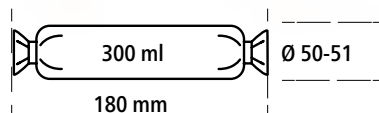

MODELO	L.TUBO	SALCHICHÓN	CARTUCHO	PESO
PSR-450	450	300-400 ml	300-310 ml	1,3



Infladores

60GT1-1

Norma UNE EN 12645:2014



- Ø 80 mm, certificado según el decreto 237327 del 13/10/20, para uso profesional.
- El cuerpo del manómetro está protegido por un capuchón de goma que facilita su conservación.
- Presión de trabajo de 0 a 10 bar.

MODELO	PRESIÓN	MANGUERA
60GT1-1	0 - 10 bar	1 m

DT-100

Verificador Presión



MODELO	PRESIÓN	PRECISIÓN
DT-100	0 - 7 bar	99%

A50106/0

- Ø 63 mm, manguera de 80 mm longitud.

MODELO	PRESIÓN	LONGITUD MANGUERA
A50106/0	0 - 10 bar	0,5 m



Máquinas con eje de cuadradillo

02

AIXIA
www.aixia.es

Llaves de carraca	58
Llaves de impacto 3/8"	62
Llaves de impacto 1/2"	64
Llaves de impacto 3/4"	69
Llaves de impacto 1"	71
Vasos de impacto y accesorios	76
Kit vasos de impacto	82



Llaves de carraca



Los modelos CP con sus cabezales extrafinos y estrechos permiten el acceso a posiciones difíciles.

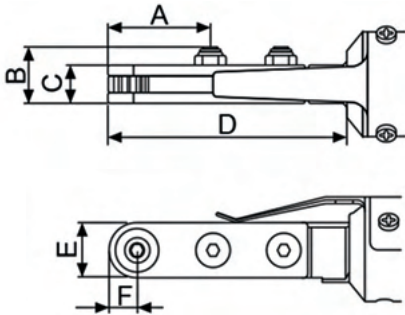

MODELO	A	B	C	D	E	F
CP-19	51	26	18	115	33,2	16,6
CP-27	59	26	18	123	41	20,5
CP-10	38,2	20	13,2	88,2	20	10,2

CP-10



CP-19



CP-27



MODELO	CAPAC. MET.	PAR. NM	HEX. POSIBLES	CABEZA		↔	RPM	KG	CONS. L/M	AIRE	USO
				ANCHO	ALTO						
CP-10	M6	10	6,7,8,9,10,11,12	20	13	300	120	1,3	300	1/4	Continuo
CP-19	M12	90	10,11,12,13,14,15,16,17,18,19	33,2	18	375	150	2,45	480	1/4	Intenso
CP-27	M18	90	21,22,23,24,25,26,27	41	18	385	130	5,5	480	1/4	Intenso

Hexágono estándar que viene con la máquina.



Llaves de carraca

760



761



- Tamaño reducido, ideal para trabajos en espacios limitados.

762



- Cabezal macizo
- Doble trinquete
- Libre de polvo
- Previene la deformación
- Triplica la vida de las piezas

763



- Cabezal macizo
- Libre de polvo
- Previene la deformación
- Triplica la vida de las piezas

MODELO	PAR NM	CUADR.	CAPACIDAD	CABEZA	RPM	↔	KG	CONS.	MANG.	R.	USO
760	40	1/4	M8	31-32	230	170	0,5	160	8	1/4	Continuo
761	30	1/4	M8	31-32	300	125	0,4	160	8		Continuo
762	40	1/4	M10	27-30	250	200	0,7	170	8		Intenso
763	68	1/4	M10	27-30	350	205	0,6	170	8		Intenso



Llaves de carraca

738



- Cabezal macizo
- Libre de polvo
- Previene la deformación
- Triplica la vida de las piezas
- Cuadradillo 3/8

765

Pequeña, ligera, manejable y versátil

- Equipada con Hex de 17 mm



ADJUNTA:

- Adaptador de 3/8"
- Portapuntas de 1/4"
- Vasos de 10, 12 y 13 mm

766L

Con sus 280 mm de longitud llega donde otras no llegan.



- Cabezal macizo
- Doble trinquete
- Libre de polvo
- Previene la deformación
- Triplica la vida de las piezas

C5003 • C5004

Con protección de goma que aísla térmicamente y absorbe las vibraciones.



- Salida de aire orientable
- Menor reacción

MODELO	PAR NM	CUADR.	CAPACIDAD	CABEZA	RPM	↔	KG	CONS.	MANG.	R.	USO
765	54	-	M8	20-34	400	159	0,48	283	10	1/4	Continuo
738	68	3/8	M10	27-30	350	205	0,7	170	8		Intenso
766L	54	1/4		28-31	250	280	0,8	283	10		Continuo
C5003	82	3/8	M12	46-40	160	265	1,3	368	8		Continuo
C5004	80	1/2		46-40	160	265	1,3	368	8		Continuo



Llaves de carraca

133



- Cabezal macizo
- Libre de polvo
- Previene la deformación
- Triplica la vida de las piezas
- Doble trinquete

175

Con sistema de impacto de doble bulón minimizando la reacción de la máquina al llegar al par de apriete.



DOBLE BULÓN



132



- Cabezal macizo
- Libre de polvo
- Previene la deformación
- Triplica la vida de las piezas

135



- Cabezal macizo
- Libre de polvo
- Previene la deformación
- Triplica la vida de las piezas
- Doble trinquete

MODELO	PAR NM	CUADR.	CAPACIDAD	CABEZA	RPM	↔	KG	CONS.	MANG.	R.	USO
133	80	1/2	M12	46-40	180	276	1,2	200	8	1/4	Continuo
175	110	1/2		46-40	250	300	1,6	200			Intenso
132	122	1/2		42-40	180	315	1,5	200			Intenso
135	122	1/2		45-40	225	313	1,6	113			Continuo



Llaves de impacto 3/8"

FW-6SCX-6



MARTILLO DOBLE

FW-6SX-5



MARTILLO SIMPLE

FW-6PH-1



MARTILLO DOBLE

MODELO	CAPACIDAD	PAR MAX NM	PAR TRABAJO NM	RPM	↔	KG	CONS.	MANG.	R.	USO
FW-6SCX-6	M6	100	60	8.000	260	1,6	300	10	1/4	Intenso
FW-6SX-5	M6	120	85	10.000	223	1,1	300	10	1/4	Intenso
FW-6PH-1	M8	210	150	8.500	147	1,4	350	10	1/4	Intenso



Llaves de impacto 3/8"

136

MARTILLO
SIMPLE

137P



DOBLE BULÓN

138PH



DOBLE MAZA

MODELO	CAPACIDAD	PAR MAX NM	PAR TRABAJO NM	RPM	↔	KG	CONS.	MANG.	R.	USO
136	M10	180	140	10.000	175	1,0	280	8	1/4	Ocasional
137P	M10	300	210	9.000	127	1,5	280	8	1/4	Ocasional
138PH	M10	400	270	10.000	140	1,4	280	8	1/4	Continuo



Llaves de impacto 1/2"

140PH

Potente, duradera y ligera



DOBLE MAZA

- Cuerpo en composite lo que reduce el peso de la máquina y mejora el aislamiento térmico.

245AC

MAZA

714PHG

Cabezal abatible



360°

60°



DOBLE MAZA

130PH

- Kit con cuadradillo de 3/8" y 1/2"
- Dos portapuntas de 8 y 10 mm
- Vasos de 13, 17, 19 y 21 mm

MODELO	CAPACIDAD	PAR MAX NM	PAR TRABAJO NM	RPM	↔	KG	CONS.	MANG.	R.	USO
140PH	M12	583	330	9.000	153	1,1	300	10	1/4	Intenso
245AC	M13	325	220	7.000	341	1,6	400			Intenso
714PHG	M13	500	450	8.000	85	1,4	400			Intenso
130PH	M16	813	545	8.000	86	1,35	430			Continuo



Llaves de impacto 1/2"

129PH

Potente, duradera y ligera



MAZA

139PH

DOBLE MAZA

164PH

MAZA

167PH

MAZA



- Cuerpo en composite lo que reduce el peso de la máquina y mejora el aislamiento térmico.

MODELO	CAPACIDAD	PAR MAX NM	PAR TRABAJO NM	RPM	↔	KG	CONS.	MANG.	R.	USO
129PH	M16	1.139	670	9.500	97	1,7	480	10	1/4	Intenso
139PH	M16	542	390	11.500	122	1,5	300			Intenso
164PH	M16	756	475	8.000	115	1,28	142			Intenso
167PH	M16	835	560	10.000	120	1,2	139			Intenso



Llaves de impacto 1/2"

150P



DOBLE BULÓN

155PH/C • 155PHRE



DOBLE MAZA

► El modelo 155PHRE con manguera silenciadora.

156PH



DOBLE MAZA

MODELO	CAPACIDAD	PAR MAX NM	PAR TRABAJO NM	RPM	↔	KG	CONS.	MANG.	R.	USO
150P	M16	615	542	7.000	180	2,3	300	10	1/4	Continuo
155PH/C	M16	860	550	7.000	186	2,7	300			Intenso
155PHRE	M16	860	550	7.000	186	2,7	300			Intenso
156PH	M16	810	540	7.000	190	2,8	150			Continuo



Llaves de impacto 1/2"

155PHK



COMPOSICIÓN DE MALETÍN

- Vasos: 9-10-11-13-14-17-19-22-24-27
- Alargadera: 75 mm
- STB
- Racor conexión



DOBLE MAZA

1001KP



COMPOSICIÓN DE MALETÍN

- Vasos: 9-10-11-13-14-17-19-22-24-27
- Alargadera: 125 mm
- STB
- Racor conexión



MARTILLO
SIMPLE

MODELO	CAPACIDAD	PAR MAX NM	PAR TRABAJO NM	RPM	↔	KG	CONS.	MANG.	R.	USO
155PHK	M16	860	550	7.000	186	2,7	300	10	1/4	Intenso
1001KP	M16	430	370	7.200	193	2,2	300			Ocasional



Llaves de impacto 1/2"

161PH



DOBLE MAZA

- Cuerpo en composite lo que reduce el peso de la máquina y mejora el aislamiento térmico.

162PH



DOBLE MAZA

- Cuerpo en composite lo que reduce el peso de la máquina y mejora el aislamiento térmico.

165PH



DOBLE MAZA

- Cuerpo en composite lo que reduce el peso de la máquina y mejora el aislamiento térmico.

160PH



DOBLE MAZA

MODELO	CAPACIDAD	PAR MAX NM	PAR TRABAJO NM	RPM	↔	KG	CONS.	MANG.	R.	USO
161PH	M19	1.356	680	8.000	178	2,1	400	10	1/4	Intenso
162PH	M19	1.800	1.125	7.000	195	2,3	200			Continuo
165PH	M19	1.112	780	7.000	183	1,9	400			Intenso
160PH	M19	1.215	950	7.000	217	3,0	400			Intenso



Llaves de impacto 3/4"

170P

DOBLE MAZA

220P

DOBLE MAZA

220PK

DOBLE MAZA

COMPOSICIÓN DE MALETÍN

Vasos: 26, 27, 29, 30, 32, 35, 36, 38

220P-6

DOBLE MAZA

MODELO	CAPACIDAD	PAR MAX NM	PAR TRABAJO NM	RPM	↔	KG	CONS.	MANG.	R.	USO
170P	M21	1.100	810	7.000	217	3,0	400	10	1/4	Intenso
220P	M25	1.356	1.030	5.000	230	4,8	400	10	1/4	Intenso
220PK	M25	1.356	1.030	5.000	230	4,8	400	10	1/4	Intenso
220P-6	M25	1.356	1.030	5.000	340	5,2	400	10	1/4	Intenso



Llaves de impacto 3/4"

260PH



DOBLE MAZA

260P-6



DOBLE MAZA

265PH



DOBLE MAZA

266PH

Bajo consumo de aire



DOBLE MAZA

MODELO	CAPACIDAD	PAR MAX NM	PAR TRABAJO NM	RPM	↔	KG	CONS.	MANG.	R.	USO
260PH	M27	1.970	1.491	5.500	220	5,5	640	13	3/8	Intenso
260P-6	M27	1.970	1.500	5.500	347	6,2	640	13	3/8	Intenso
265PH	M27	2.180	1.650	6.000	215	3,3	650	13	3/8	Intenso
266PH	M25	2.000	1.650	5.600	220	3,8	260	13	3/8	Continuo



Llaves de impacto 1"

270PH

DOBLE MAZA

271PH

Bajo consumo de aire



DOBLE MAZA

272PH

DOBLE MAZA

272PHL

DOBLE MAZA

MODELO	CAPACIDAD	PAR MAX NM	PAR TRABAJO NM	RPM	↔	KG	CONS.	MANG.	R.	USO
270PH	M27	1.970	1.500	5.500	220	5,5	640	13	3/8	Intenso
271PH	M27	1.500	1.250	4.500	250	7,3	260	13	1/2	Continuo
272PH	M33	2.500	2.034	5.300	250	5	650	13	3/8	Intenso
272PHL	M33	2.500	2.034	5.300	400	5,8	650	13	3/8	Intenso



Llaves de impacto 1"

BIG-322P



BIG-322P-8



BIG-452P



BIG-452P-8



MODELO	CAPACIDAD	PAR MAX NM	PAR TRABAJO NM	RPM	↔	KG	CONS.	MANG.	R.	USO
BIG-322P	M38	3.150	2.500	4.300	265	9,5	770	13	3/8	Intenso
BIG-322P-8	M38	3.150	2.500	4.300	430	10,4	770	13	3/8	Intenso
BIG-452P	M45	3.850	3.100	2.900	322	14,2	850	13	3/8	Intenso
BIG-452P-8	M45	3.850	3.100	2.900	510	16,2	850	13	3/8	Intenso



Llaves de impacto 1"

278S



DOBLE MAZA

Compacta, ligera y con potencia suficiente para trabajos exigentes.

- Bajo consumo de aire



278SL



DOBLE MAZA

Compacta, ligera y con potencia suficiente para trabajos exigentes.

- Bajo consumo de aire



320SL



DOBLE MAZA

MODELO	CAPACIDAD	PAR MAX NM	PAR TRABAJO NM	RPM	↔	KG	CONS.	MANG.	R.	USO
278S	M33	2.440	2.030	6.000	354	6,3	226	13	1/2	Continuo
278SL	M33	2.440	2.030	6.000	497	7,1	226	13	1/2	Continuo
320SL	M33	2.500	2.075	4.400	520	12,2	350	13	3/8	Continuo



Llaves de impacto 1"

330S



DOBLE MAZA

330SL

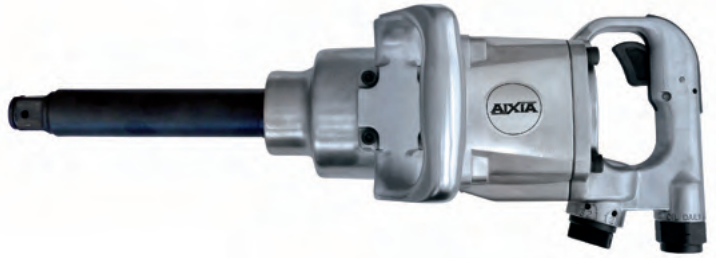

DOBLE MAZA

BIG-322SA-2



MARTILLO
SIMPLE

BIG-322SA

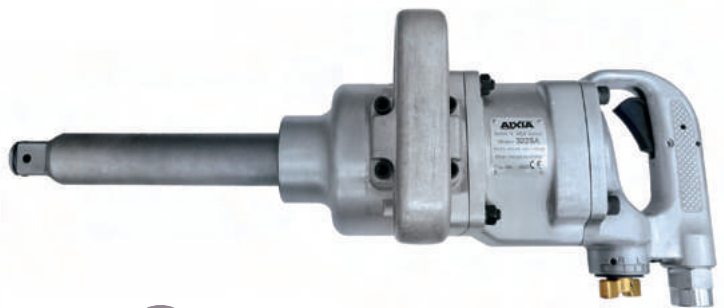

MARTILLO
SIMPLE

MODELO	CAPACIDAD	PAR MAX NM	PAR TRABAJO NM	RPM	↔	KG	CONS.	MANG.	R.	USO
330S	M33	2.750	2.200	4.000	360	10,5	360	13	3/8	Intenso
330SL	M33	2.750	2.200	4.000	520	11,3	600	13	3/8	Intenso
BIG-322SA-2	M38	3.150	2.500	4.400	350	10,4	770	13	1/2	Intenso
BIG-322SA	M38	3.150	2.500	4.400	515	11,0	770	13	1/2	Intenso



Llaves de impacto 1" y 1-1/2"

BIG-45SA-2



MARTILLO
SIMPLE

LATIGUILLO ANTIVIBRATORIO



Recomendamos el uso de este accesorio para evitar la transmisión directa de la vibración desde la manguera al enchufe, evitando así el deterioro de la válvula y la consecuente pérdida involuntaria de aire.

Aconsejamos su uso en pistolas de impacto y martillos (cinceladores, de agujas...)

BIG-45SA



MARTILLO
SIMPLE

MODELO	R.	SERIE DEL ENCHUFE	Ø MANG.
LAT 1/4 - 24	1/4	24	10
LAT 1/4 - 26	1/4	26	10
LAT 3/8 - 26	3/8	26	10
LAT 3/8 - 30	3/8	30	10
LAT 1/2 - 30	1/2	30	13
LAT 1/2 - 37	1/2	37	13

BIG-551SA



DOBLE BULÓN

MODELO	□	CAPACIDAD	PAR MAX NM	PAR TRABAJO NM	RPM	↔	KG	CONS.	MANG.	R.	USO
BIG-45SA-2	1	M45	3.928	3.300	3.150	475	15,5	850	13	1/2	Intenso
BIG-45SA	1	M45	3.925	3.300	3.150	665	17,0	850	13	1/2	Intenso
BIG-551SA	1-1/2	M50	5.325	4.100	3.600	520	17,8	850	13	1/2	Intenso



Vasos de impacto 1/4" y accesorios



PROLONGADORES

MODELO	RETEN.	□	□	L
P2X-50	Bola	1/4	1/4	50
P2X-75P	Pincho			75
P2X-150	Bola			150
P3X-50P	Pincho	3/8	3/8	50
P3X-75	Bola			75
P3X-75P	Pincho			75
P3X-100P	Pincho			100
P3X-125	Bola			125
P3X-125P	Pincho			125
P3X-150P	Pincho	150		
P3X-250	Bola	250		
P3X-250P	Pincho	250		
P4X-50	Bola	1/2	1/2	50
P4X-75				75
P4X-125				125
P4X-150				150
P4X-250				250
P6X-100		3/4	3/4	100
P6X-175				175
P6X-200				200
P6X-250				250
P6X-300		300		
P8X-175	1	1	175	
P8X-250			250	
P8X-300			300	
P8X-330			330	



ADAPTADORES

MODELO	RETEN.	□	MACHO	L
PAD-2-3	Bola	1/4	3/8	26
PAD-3-2	Bola	3/8	1/4	32
PAD-3-4	Bola	3/8	1/2	36
PAD-3-4P	Pincho	3/8	1/2	36
PAD-4-3P	Pincho	1/2	3/8	38
PAD-4-3	Bola	1/2	3/8	38
PAD-4-6	Bola	1/2	3/4	48
PAD-6-4	Bola	3/4	1/2	56
PAD-6-8	Bola	3/4	1	63
PAD-8-6	Bola	1	3/4	75
PAD-8-12	Bola	1	1-1/2	90
PAD-12-8	Bola	1-1/2	1	100



LARGOS IMÁN RETRACTIL

MODELO	□	○	∅	L
P205MAG-L50	1/4	5	8,8	50
P206MAG-L50		6	10	
P207MAG-L50		7	11,3	
P208MAG-L50		8	12,5	
P210MAG-L50		10	15	



ARTICULACIONES

MODELO	RETEN.	□	□	L
P2UJB	Bola	1/4	1/4	43
P3UJB		3/8	3/8	50
P4UJB		1/2	1/2	60
P6UJB		3/4	3/4	105
P8UJB		1	1	133



CORTOS IMÁN

Hexagonal y Torx

MODELO	□	○	∅	L
P2-06MAG	HEX 1/4	6	10	23
P2-07MAG		7	11,3	
P2-08MAG		8	12,5	
P2-10MAG		10	15	
P2-13MAG		13	18,8	
P2-E8MAG	TORX 1/4	E8	10	25

CORTOS

MODELO	□	○	∅	L
P2-05M	1/4	5	8,8	23
P2-05,5M		5,5	9,5	
P2-06M		6	10	
P2-07M		7	11,3	
P2-08M		8	12,5	
P2-09M		9	13,8	
P2-10M		10	15	
P2-11M		11	16,3	
P2-12M		12	17	
P2-13M		13	18,8	

ESPECIALES FERROCARRIL

MODELO	□	□	∅	L
P821M4	1"	21	52	57



MODELO	□	□	∅	L
P821x28M	1"	21x28	62	70





Vasos de impacto 3/8"



CORTOS

MODELO	□	○	∅	L
P3-06M	3/8	6	10,5	30
P3-07M		7	11,5	
P3-08M		8	12,5	
P3-09M		9	14	
P3-10M		10	15	
P3-11M		11	17	
P3-12M		12	17,5	
P3-13M		13	19	
P3-14M		14	20	
P3-15M		15	22	
P3-16M		16	24	
P3-17M		17	25	
P3-18M		18	26	
P3-19M		19	27,5	
P3-20M	20	28		



CORTOS IMÁN

MODELO	□	○	∅	L
P3-08MAG	3/8	8	14	30
P3-10MAG		10	16,5	
P3-12MAG		12	19	
P3-13MAG		13	20	
P3-16MAG		16	24	



LARGOS

MODELO	□	○	∅	L
P3-07ML	3/8	7	12,5	65
P3-08ML		8	13,8	
P3-09ML		9	15	
P3-10ML		10	16	
P3-11ML		11	17,5	
P3-12ML		12	19	
P3-13ML		13	20	
P3-14ML		14	21	
P3-15ML		15	22	
P3-16ML		16	24	
P3-17ML		17	25	
P3-18ML		18	26	
P3-19ML		19	27,5	



LARGOS IMÁN RETRACTIL

MODELO	□	○	∅	L
P306MAG-L55	3/8	6	11,5	55
P307MAG-L55		7	12,5	
P308MAG-L55		8	14	
P310MAG-L55		10	16,5	
P313MAG-L55		13	20	



TORX EXTERIOR

MODELO	□	○	∅	L
P3-E5	3/8	E5	9	32
P3-E6		E6	10	
P3-E7		E7	10	
P3-E8		E8	10,5	
P3-E10		E10	12,5	
P3-E12		E12	15	
P3-E14		E14	17	



TORX EXTERIOR CON IMÁN

MODELO	□	○	∅	L
P3-E10MAG	3/8	E10	13	32
P3-E12MAG		E12	15	
P3-E14MAG		E14	17,5	



ARTICULADOS

MODELO	□	○	∅	L
P3US-10M	3/8	10	15	53
P3US-11M		11	17	
P3US-12M		12	19	
P3US-13M		13	20	
P3US-14M		14	21	



PUNTA HEXAGONAL

MODELO	□	○	L. HEX	L
P3H-04M	3/8	4	16	50
P3H-05M		5		
P3H-06M		6		
P3H-08M		8		
P3H-10M		10		



Vasos de impacto 1/2"



CORTOS

MODELO	□	○	∅	L	
P4-08M	1/2	8	14	38	
P4-09M		9	15		
P4-10M		10	16		
P4-11M		11	17,5		
P4-12M		12	19		
P4-13M		13	20		
P4-14M		14	22		
P4-15M		15	23		
P4-16M		16	25		
P4-17M		17	26		
P4-18M		18	26		
P4-19M		19	28		
P4-20M		20	28		
P4-21M		21	30		
P4-22M		22	32		
P4-23M		23	32		
P4-24M		24	35		45
P4-25M		25	36		
P4-26M		26	38	50	
P4-27M		27	38,7		
P4-28M		28	40		
P4-29M		29	40		
P4-30M		30	42		
P4-32M		32	44		
P4-33M		33	45		
P4-34M		34	47		
P4-35M		35	48		
P4-36M		36	49		



CORTOS DOBLE HEXAGONO

MODELO	□	○	∅	L	
P4-08M2	1/2	8	15	38	
P4-10M2		10	17		
P4-11M2		11	18		
P4-12M2		12	19		
P4-13M2		13	20		
P4-14M2		14	22		
P4-15M2		15	24		
P4-16M2		16	24		
P4-17M2		17	26		
P4-18M2		18	26		
P4-19M2		19	28		
P4-21M2		21	30		
P4-22M2		22	32		
P4-23M2		23	32		
P4-24M2		24	34		45
P4-27M2		27	38		
P4-30M2		30	42		50
P4-32M2		32	44		



LARGOS

MODELO	□	○	∅	L
P4-10ML	1/2	10	17,5	78
P4-11ML		11	18,7	
P4-12ML		12	20	
P4-13ML		13	21	
P4-14ML		14	22,5	
P4-15ML		15	23,7	
P4-16ML		16	25	
P4-17ML		17	26	
P4-18ML		18	27,5	
P4-19ML		19	28,7	
P4-21ML		21	30	
P4-22ML		22	32	
P4-23ML		23	32	
P4-24ML		24	35	
P4-26ML		26	38	
P4-27ML		27	38,7	
P4-30ML		30	42	
P4-32ML		32	44	



LARGOS REBAJADOS

MODELO	□	○	∅	L
P4-17MLR	1/2	17	24	78
P4-19MLR		19	26	
P4-21MLR		21	28	



LARGOS REBAJADOS CON FUNDA Y TAPON DE PLASTICO

MODELO	□	○	∅	L
P4-17MLRP	1/2	17	26,7	85
P4-19MLRP		19	28,7	
P4-21MLRP		21	30,7	
P4-22MLRP		22	32,5	



PUNTA HEXAGONAL

MODELO	□	P. HEX	L. HEX	L
P4H-04M	1/2	4	20	75
P4H-05M		5		
P4H-06M		6		
P4H-08M		8	25	
P4H-10M		10		
P4H-12M		12		
P4H-14M		14		
P4H-17M		17		
P4H-19M		19		



Vasos de impacto 1/2"



PUNTA TORX

MODELO	□	P. TORX	L. TORX	L
P4-T20	1/2	T20	25	55
P4-T25		T25		
P4-T27		T27		
P4-T30		T30		
P4-T40		T40		
P4-T45		T45		
P4-T47		T47		
P4-T50		T50		
P4-T55		T55		
P4-T60		T60		
P4-T70		T70		



KIT EXTRACTOR TUERCAS ANTIRROBO

MODELO	□	VASO EXTRACTOR
69782507	1/2	17 mm
69782510		18,5 mm
69782513		20 mm
69782516		21,5 mm
69782520		23 mm
69782523		24,5 mm
69782526		26 mm



TORX EXTERIOR

MODELO	□	⊕	∅	L
P4-E10	1/2	E10	15	38
P4-E12		E12	16	
P4-E14		E14	18,5	
P4-E16		E16	20	
P4-E18		E18	22	
P4-E20		E20	25	
P4-E22		E22	26,5	
P4-E24	E24	28,5		



BARRAS DE TORSIÓN Y VASOS

MODELO	□	COMPOSICIÓN	
68221G07	1/2	Barra de torsión	90 Nm Amarillo
68221L07		Barra de torsión	110 Nm Azul
68221M07		Barra de torsión	135 Nm Gris
68221P07		Barra de torsión	160 Nm Blanco
68221R07		Barra de torsión	190 Nm Agua



ARTICULADOS

MODELO	□	⊕	∅	L
P4US-13M	1/2	13	20	65
P4US-14M		14	22	
P4US-17M		17	26	
P4US-19M		19	28	



Vasos de impacto 3/4"



CORTOS

MODELO	□	○	∅	L
P6-17M	3/4	17	28,5	50
P6-18M		18	29,5	
P6-19M		19	30	
P6-20M		20	32	
P6-21M		21	32	
P6-22M		22	34	
P6-23M		23	35	52
P6-24M		24	36	
P6-25M		25	38	
P6-26M		26	40	
P6-27M		27	40	
P6-28M		28	42	
P6-29M		29	42	
P6-30M		30	44	
P6-32M		32	44	
P6-33M		33	47	
P6-35M		35	50	
P6-36M		36	51	
P6-38M		38	53	
P6-41M		41	58	62
P6-42M		42	61	
P6-46M		46	67	63
P6-50M		50	71	72
P6-55M		55	77	75
P6-60M		60	84	75
P628		7/8	36	50
P630		15/16	38	50
P636		1-1/8	44	53
P642		1-5/16	50	56



LARGOS

MODELO	□	○	∅	L
P6-17ML	3/4	17	31	95
P6-19ML		19	33	
P6-21ML		21	35	
P6-22ML		22	37	
P6-23ML		23	38	
P6-24ML		24	39	
P6-26ML		26	41	
P6-27ML		27	43	
P6-28ML		28	44	
P6-29ML		29	45	
P6-30ML		30	47	
P6-32ML		32	49	
P6-33ML		33	51	
P6-35ML		35	53	
P6-36ML		36	54	
P6-38ML		38	57	
P6-41ML		41	60	
P6-46ML		46	67	
P6-50ML		50	71	



CORTOS DOBLE HEXAGONO

MODELO	□	○	∅	L
P6-17M2	3/4	17	28	50
P6-18M2		18	29	
P6-19M2		19	30	
P6-21M2		21	32	
P6-22M2		22	34	
P6-23M2		23	35	
P6-24M2		24	36	52
P6-26M2		26	40	
P6-27M2		27	40	
P6-28M2		28	42	
P6-29M2		29	43	
P6-30M2		30	43	
P6-32M2		32	45	56
P6-33M2		33	46	
P6-36M2		36	51	
P6-38M2		38	53	
P6-40M2		40	59	58
P6-41M2		41	58	62
P6-42M2		42	61	
P6-46M2		46	67	68



PUNTA HEXAGONAL

MODELO	□	○	L.HEX	L
P6H-10M	3/4	10	20	100
P6H-12M		12		
P6H-14M		14		
P6H-17M		17		
P6H-19M		19		
P6H-22M		22		
P6H-24M		24		
P6H-27M		27		



Vasos de impacto 1" y 1-1/2"



CORTOS

MODELO	□	○	∅	L	
P8-21M	1"	21	38	58	
P8-22M		22	39		
P8-23M		23	40		
P8-24M		24	40		
P8-26M		26	42,5		
P8-27M		27	44		
P8-28M		28	45	60	
P8-29M		29	46		
P8-30M		30	48		
P8-32M		32	51		
P8-33M		33	53		62
P8-34M		34	55		
P8-35M		35	54		
P8-36M		36	56		
P8-38M		38	58		
P8-41M		41	61,5	64	
P8-42M		42	63		
P8-46M		46	68		
P8-50M		50	73		70
P8-52M		52	75		
P8-54M	54	78			
P8-55M	55	79	72		
P8-58M	58	85	75		
P8-60M	60	87	78		
P8-65M	65	93	80		
P8-70M	70	98	85		
P8-75M	75	104	98		
P8-80M	80	109	100		
P8-85M	85	115			
P8-90M	90	125	105		
P828	7/8	31	56		
P830	15/16	40	56		
P842	1-5/16	53	64		



LARGOS

MODELO	□	○	∅	L
P8-21ML	1"	21	37,5	100
P8-22ML		22	40	
P8-23ML		23	41	
P8-24ML		24	42	
P8-26ML		26	44,5	
P8-27ML		27	46	
P8-28ML		28	47	
P8-29ML		29	48	
P8-30ML		30	50	
P8-32ML		32	52	
P8-33ML		33	53	105
P8-34ML		34	55	
P8-35ML		35	55	
P8-36ML		36	56	
P8-38ML		38	59	
P8-41ML		41	63	
P8-42ML		42	64	
P8-46ML		46	69	
P8-50ML		50	74	
P8-52ML		52	77	
P8-54ML	54	79	105	
P8-55ML	55	80	120	
P8-58ML	58	84	125	
P8-60ML	60	86	125	
P8-65ML	65	93	125	
P8-70ML	70	100	125	



LARGOS REBAJADOS

MODELO	□	○	∅	L
P8-27MLR	1"	27	42,5	100
P8-30MLR		30	45	
P8-32MLR		32	47	
P8-33MLR		33	49	

CORTOS 1-1/2"

MODELO	□	○	∅	L
P12-041M	1-1/2"	41	70	80
P12-046M		46	76	84
P12-050M		50	81	87
P12-055M		55	86	90
P12-060M		60	93	92
P12-065M		65	97	95
P12-070M		70	105	100
P12-075M		75	110	103
P12-080M		80	116	110
P12-085M		85	125	118
P12-090M		90	130	118
P12-095M		95	137	118
P12-100M		100	140	125
P12-105M		105	150	125
P12-110M		110	156	125
P12-115M		115	160	135
P12-120M		120	168	135



PUNTA HEXAGONAL

MODELO	□	○	L.HEX	L
P8H-14M	1"	14	20	100
P8H-17M		17		
P8H-19M		19		
P8H-22M		22		
P8H-24M		24		
P8H-27M		27		
P8H-28M		28		
P8H-30M		30		
P8H-32M		32		



Kit vasos de impacto

KIT BARRAS DE TORSIÓN Y VASOS

MODELO	<input type="checkbox"/>	COMPOSICIÓN
KT-409	1/2	VASOS: P417MLRP, P419MLRP, P421MLRP, P422MLRP BARRAS DE TORSIÓN: 68221G07 (90Nm), 68221L07 (110Nm), 68221M07 (135Nm), 68221P07 (160Nm), 68221R07 (190Nm)



KIT VASOS LARGOS REBAJADOS CON FUNDA Y TAPÓN DE PLÁSTICO

MODELO	<input type="checkbox"/>	COMPOSICIÓN
KP-403	1/2	P417MLRP P419MLRP P421MLRP



KIT VASOS TORX MACHO

MODELO	<input type="checkbox"/>	COMPOSICIÓN
P4TK	1/2	P4-T20, P4-T25, P4-T27, P4-T30, P4-T40, P4-T45, P4-T47, P4-T50, P4-T55, P4-T60, P4-T70



KIT VASOS CORTOS

MODELO	<input type="checkbox"/>	COMPOSICIÓN
81940A	1/2	P411M, P412M, P413M, P414M, P416M, P417M, P419M, P421M, P422M



KIT VASOS ALLEN

MODELO	<input type="checkbox"/>	COMPOSICIÓN
P4HK	1/2	P4H04M, P4H05M, P4H06M, P4H08M, P4H10M, P4H12M, P4H14M, P4H17M, P4H19M





Kit vasos de impacto

KIT VASOS CORTOS

MODELO	<input type="checkbox"/>	COMPOSICIÓN
P4-17KIT	1/2	VASOS: P409M, P410M, P411M, P412M, P413M, P414M, P415M, P416M, P417M, P418M, P419M, P420M, P421M, P422M, P423M, P424M, P425M ARTICULACION: P4UJB PROLONGADORES: P4X-125, P4X-250
P6-17KIT	3/4	VASOS: P622M, P623M, P624M, P625M, P627M, P628M, P629M, P630M, P632M, P633M, P636M, P638M, P641M, P642M, P646M, P650M ARTICULACION: P6UJB PROLONGADORES: P6X-175, P6X-200



KIT VASOS LARGOS

MODELO	<input type="checkbox"/>	COMPOSICIÓN
K-804ML	1"	P827ML, P830ML, P832ML, P833ML



KIT VASOS ALLEN

MODELO	<input type="checkbox"/>	COMPOSICIÓN
P3HK	3/8	P3H04M, P3H05M, P3H06M, P3H07M, P3H08M, P3H10M, P3H12M



KIT EXTRACTOR TUERCAS ANTIRROBO

MODELO	<input type="checkbox"/>	COMPOSICIÓN
KE-407	1/2	69782507 (17 mm), 69782510 (18,5 mm), 69782513 (20 mm), 69782516 (21,5 mm), 69782520 (23 mm), 69782523 (24,5 mm), 69782526 (26 mm)



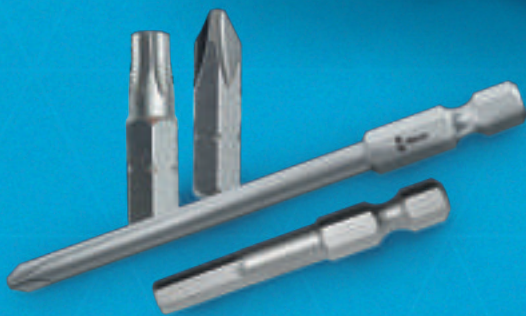

Máquinas para montaje

03



Puntas	86
Equilibradores	92
Atornilladores	96
Taladros	104
Roscadoras	112
Remachadoras	114



Portapuntas • Extensiones • Vasos

ADAPTADOR MAGNÉTICO



MODELO	Ø	Ø	L
ARBH-423M	1/4	1/4	75
ARBH-44M			102
ARBH-46M			152
ARBH-48M			203

CAMBIO RÁPIDO MAGNÉTICO



MODELO	Ø	Ø	L
BH1-0860	1/4	1/4	60

ADAPTADOR MAGNÉTICO



MODELO	Ø	Ø	L
3514M/70	7/16	1/4	70

ADAPTADOR MAGNÉTICO



MODELO	Ø	Ø	L
3414M/54	5/16	1/4	54

EXTENSIÓN-ADAPTADOR



MODELO	Ø	Ø	L
ARX-5002	1/4	1/4	51
ARX-5003			76
ARX-5004			102
ARX-5005			152
ARX-5012			51
ARX-5013		76	
ARX-5014		102	
ARX-5015		152	
ARX-5022		1/2	50
ARX-5023			75

ADAPTADOR CON IMÁN



Ultrapotente

MODELO	Ø	Ø	L
MBC	1/4	1/4	72

ADAPTADOR



MODELO	Ø	Ø	L
PAD-1414	3/8	1/4	26
PAD-3814		1/4	32
PAD-3816		5/16	37
PAD-1214	1/2	1/4	40
PAD-1216		5/16	40

ADAPTADOR CONEXIÓN RÁPIDA



MODELO	Ø	Ø	L
PAD-3814 RAP	3/8	1/4	41
PAD-1214 RAP	1/2	1/4	41

VASO MAGNÉTICO



Para tornillos autoroscantes

MODELO	Ø	Ø	L
ARVS4841M	1/4	8	43
ARVS4041M		10	45
ARVS4315M		3/8	

VASO CON EXTENSIÓN MAGNÉTICO



MODELO	Ø	Ø	L
AR1306/50M	1/4	6	50
AR1307/65M		7	65
AR1308/50M		8	50
AR1310/50M		10	55
AR1313/50M		13	
1314/50M		14	50
1355/75M		5,5	75
AR1308/75M		8	
AR1310/75M		10	

VASO CON EXTENSIÓN SIN IMÁN



MODELO	Ø	Ø	L
1306/50	1/4	6	50
AR1308/50		8	
AR1310/50		10	
AR1312/50		12	55
AR1313/50		13	
AR1307/65		7	65
1308/75		8	75
AR1310/75		10	
1306/100		6	
1308/100		8	



Puntas Phillips

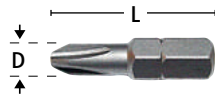

MODELO	Ø	PXD	L
AR3000R/25	1/4	0 x 3	25
AR3001R/25		1 x 4,5	
AR1012		2 x 4,5	
AR3002R/25		2 x 5	
AR1002P		2 x 6	50
3001R/50		1 x 4,5	
3002R/50		2 x 6	
3002R/75		2 x 6	



MODELO	Ø	P	L
AR1001	1/4	1	25
AR1002		2	
AR1003		3	
AR1022		2	38
AR1032		2	49
AR1042		2	63



MODELO	Ø	P	L
D1001	1/4	1	30
D1002		2	
D1003		3	



MODELO	Ø	P	L
413031	1/4	1	65
AR413042		2	
413052		3	
425040		2	75
425049		2	150



MODELO	Ø	PXD	L
AR10600	1/4	00 x 1,5	50
AR1060		0 x 3,2	
AR1061		1 x 4,5	
AR1062R		2 x 4,5	
AR1062		2 x 6,3	
AR1063		3 x 8	
AR1071		1 x 4,5	70
AR1072R		2 x 4,7	
AR1072		2 x 6,3	75
AR1073		3 x 6	
AR1081		1 x 4,5	100
AR1082R		2 x 4,7	
AR1082		2 x 6,3	
AR1083		3 x 8	
AR1091		1 x 4,5	152
AR1092R		2 x 4,7	
AR1092		2 x 6,3	

+ TORSIÓN



MODELO	Ø	PXD	L
1072Torsion	1/4	3 x 6,3	70
1082Torsion		2 x 6,3	90

+ TORSIÓN ROSCADA



MODELO	Ø	PXD	L
AR3592/34	1/4	2 x M5	34
AR3592/45		2 x M5	45

+ 5/16 DESTORGOLPE



MODELO	Ø	PXD	L
AR431051	5/16	3 x 6,35	36
AR431061		4 x 6,35	



Puntas Pozidriv



MODELO	Ø	P	L
AR1001PZ	1/4	1	25
AR1002PZ		2	
AR1003PZ		3	



MODELO	Ø	P	L
D1001PZ	1/4	1	30
D1002PZ		2	
D1003PZ		3	



MODELO	Ø	P X D	L
AR1061PZ	1/4	1 x 4,5	50
AR1062PZ		2 x 6,3	
AR1063PZ		3 x 8	
1073PZ		3 x 8	70
AR1071PZ		1 x 4,5	75
AR1072PZ		2 x 6,3	
AR1081PZ		1 x 4,5	89
AR1082PZ		2 x 6,3	
AR1092PZ		2 x 6,3	152

CONSEJOS SOBRE PUNTAS

Las puntas son consideradas productos de consumo, con un uso adecuado, alargará su vida útil y evitará roturas o desgastes acelerados.

A continuación les indicamos los problemas más frecuentes, sus causas y remedios.

ROTURA DE LA PUNTA

MOTIVO

- Tornillo de mala calidad (medidas sin precisión adecuada).
- La medida de la punta no coincide con la del tornillo.
- Inserción incompleta de la punta en el tornillo.
- Aplicar la punta sobre el tornillo con un ángulo inadecuado.
- Dureza excesiva de la punta.
- Eje del atornillador o portapuntas desgastado.
- Apriete excesivo.
- Seguir apretando cuando el par de apriete está alcanzado.
- Levantar el atornillador cuando está girando el eje.

REMEDIO

- Utilice tornillos de calidad (DIN, ISO, JIS, etc.).
- Verifique que utiliza la punta adecuada al tornillo.
- Verificar la inserción de la punta antes de accionar el atornillador.
- Aplicar la punta sobre el tornillo con el ángulo correcto.
- Utilice puntas con la dureza adecuada.
- Reemplazar el eje del atornillador o el portapuntas.
- Verifique y ajuste el apriete de su atornillador.
- El tiempo estandar de apriete suele ser de 2-3 segundos.
- Verificar que el atornillador no gira antes de levantarlo.

DESGASTE ACELERADO DE LA PUNTA

MOTIVO

- Tornillo de mala calidad (medidas sin precisión adecuada).
- La medida de la punta no coincide con la del tornillo.
- Inserción incompleta de la punta en el tornillo.
- Dureza inadecuada de la punta.
- Eje del atornillador o portapuntas desgastado.

REMEDIO

- Utilice puntas de calidad (DIN, ISO, JIS, etc.).
- Verifique que utiliza la punta adecuada al tornillo.
- Verificar la inserción de la punta antes de accionar el atornillador.
- Utilice puntas con la dureza adecuada.
- Reemplazar el eje del atornillador o el portapuntas.



Puntas planas



MODELO	Ø	AXE	L
AR5603/25	1/4	3,0 x 0,50	25
AR5635/25		3,5 x 0,55	
AR1502		5,5 x 0,80	
AR1503		6,0 x 0,85	
AR1504		7,0 x 0,90	
AR1505		8,0 x 1,00	



MODELO	Ø	AXE	L
D1500	1/4	4 x 0,60	30
D1501		5 x 0,75	
D1502		6 x 0,85	



MODELO	Ø	AXE	L
6003	1/4	7,4 x 1,07	95



MODELO	Ø	AXE	L
AR152000	1/4	3,1 x 0,56	49
AR1520		4 x 0,6	
AR1521		4,5 x 0,7	
AR1522		5,5 x 0,80	
AR1523		6,3 x 0,91	
AR153000		3,1 x 0,56	
AR15300		3,4 x 0,66	
AR1530		4,0 x 0,86	
AR1531		4,7 x 0,86	
1533		6,3 x 0,91	
AR1536		7,9 x 1,17	
AR154000		3,1 x 0,56	90
AR1542		5,5 x 0,91	90
AR1540		4 x 0,81	100



MODELO	Ø	AXE	L
1511	5/16	4,75 x 0,85	38
1512		5,55 x 1,02	
1513		6,35 x 1,07	
1514		7,15 x 1,17	
1515		7,94 x 1,27	
1516		9,13 x 1,40	



MODELO	Ø	A	L
431171	5/16	8	36
431271		10	
431273		12	



Puntas Allen



MODELO	Ø	Ø	L
AR21225	1/4	2,5	50
AR21203		3	
AR21204		4	
AR21205		5	
AR21206		6	



MODELO	Ø	Ø	L
AR21025	1/4	2,5	25
AR21003		3	
AR21004		4	
AR21005		5	
AR21006		6	
AR21008		8	



Puntas Torx



MODELO	Ø	T	L
ART10007	1/4	T-7	25
ART10008		T-8	
ART10010		T-10	
ART10015		T-15	
ART10020		T-20	
ART10025		T-25	
ART10027		T-27	
ART10030		T-30	
ART10040		T-40	



MODELO	Ø	T	L	
ART10610	1/4	T-10	50	
ART10615		T-15		
ART10620		T-20		
ART10625		T-25		
T10627		T-27		
ART10630		T-30		
ART10640		T-40		
ART10707		T-7		70
ART10710		T-10		75
ART10720		T-20		
ART10725	T-25			
ART10727	T-27			
ART10730	T-30			
ART10740	T-40			
T10807	T-7	89		
ART10810	T-10			
ART10815	T-15			
ART10820	T-20			
ART10830	T-30			
ART10825	T-25	100		
T10827	T-27	89		
ART10920	T-20	150		
ART10930	T-30	150		
T10907	T-7	152		
T10908	T-8			
T10909	T-9			
T10915	T-15			
T10927	T-27			
T10940	T-40			



TORX INVIOLEBLE

MODELO	Ø	T	L
ART10010H	1/4	T-10	25
ART10015H		T-15	
ART10020H		T-20	
ART10025H		T-25	
ART10027H		T-27	
ART10030H		T-30	



TORX INVIOLEBLE

MODELO	Ø	T	L
T10715H	1/4	T-15	70
T10810H		T-10	89
T10910H		T-10	152
T10915H		T-15	
T10920H		T-20	



TORX 5/16

MODELO	Ø	T	L
ART40/35	5/16	T-40	35
ART45/35		T-45	
ART50/35		T-50	
ART55/35		T-55	



IMANTADOR DE PUNTAS

MODELO	
	10495G



Puntas Wera

PUNTAS PHILIPS WERA



MODELO	Ø	⊕	L
AR1001W	1/4	PH1	25



MODELO	Ø	⊕	L
AR1062W	1/4	PH2	50
AR1072W		PH2	70
AR1082W		PH2	110

PUNTAS ALLEN WERA



MODELO	Ø	Ø	L
AR21025W	1/4	2,5	25
AR21003W		3	
AR21004W		4	
AR21005W		5	
AR21006W		6	



MODELO	Ø	Ø	L
AR21203W	1/4	3	50
AR21204W		4	
AR21205W		5	
AR21206W		6	

PUNTAS POZIDRIV WERA



MODELO	Ø	⊕	L
AR1001PZW	1/4	PZ1	25
AR1002PZW		PZ2	



MODELO	Ø	⊕	L
AR1072PZW	1/4	PZ2	70

PUNTAS TORX WERA



MODELO	Ø	☆	L
ART10010W	1/4	T-10	25
ART10015W		T-15	
ART10020W		T-20	
ART10025W		T-25	
ART10030W		T-30	
ART10040W		T-40	



Inviolable



MODELO	Ø	☆	L
ART10020HW	1/4	T-20	25
ART10025HW		T-25	
ART10030HW		T-30	



MODELO	Ø	☆	L
ART10620W	1/4	T-20	50
ART10625W		T-25	
ART10630W		T-30	





Equilibradores



Regulables
y con limitador
de carrera

- Cuerpo metálico y cable embebido en plástico

MODELO	CAP.KG	L. CABLE INOX	PESO	USO
2003-E	0,6 - 1,5	1,4 m	0,5	Continuo
2004-E	1,5 - 3		0,5	
2007-E	3 - 5		0,8	

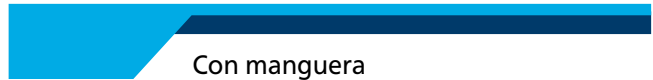

Con manguera



MODELO	CAP.KG	L. MANG POLIPROPILENO	MANG.	USO
LR-09	0,5 - 1,5	1,2 m	5 x 8	Continuo



Capacidad de trabajo regulable

- Cuerpo metálico y cable de acero
- EWT-2 con cuerpo de plástico



MODELO	CAP.KG	L. CABLE INOX	PESO	USO
EWT-2	0,5 - 1,5	1,3 m	0,7	Intenso
EWT-3	1 - 3		1,4	
EWT-5	3 - 5		1,8	
2008-E	5 - 7		1,8	
EWT-9	4,5 - 9		3,6	
EWT-15	9 - 15		3,6	



Capacidad de
trabajo regulable

- Cuerpo metálico y cable de acero



MODELO	CAP.KG	L. CABLE INOX	PESO	USO
EWT-22	15 - 22	1,5 m	7,3	Intenso
EWT-30	22 - 30		7,7	
EWF-40	30 - 40		9,7	
EWF-60	50 - 60		11,1	



Equilibradores

Equilibradores Serie 93, excepto modelo 9300-NY

- ▶ Aptos para industria alimentaria.
- ▶ Tienen capacidad de trabajo regulable y están dotados de limitador de carrera.
- ▶ Cuerpo en aluminio y cable en acero inoxidable.
- ▶ Los equipos con bloqueo permiten dejar la carga bloqueada a la altura deseada.

MODELO	CAP.KG	L. CABLE POLIPROPILENO	PESO	USO
9300NY	0,2 - 0,5	1,6 m	0,5	Intenso

MODELO	CAP.KG	L. CABLE INOX	PESO	USO
9311-E	0,4 - 1	1,6 m	0,6	Intenso
9312-E	1 - 2		0,6	
9313-E	2 - 3		0,7	
9321-E	2 - 4	2 m	2,0	
9322-E	4 - 6		2,3	
9323-E	6 - 8		2,5	
9336-E	2 - 4	2,5 m	2,9	
9337-E	4 - 6		3,2	
9338-E	6 - 8		3,5	
9339-E	8 - 10		3,7	
9340-E	10 - 14		4,0	



Con bloqueo

MODELO	CAP. KG	L. CAB INOX	PESO	USO
9346-E	2 - 4	2,5 m	3	Intenso
9347-E	4 - 6		3,3	
9348-E	6 - 8		3,6	
9349-E	8 - 10		3,8	
9350-E	10 - 14		4	





Equilibradores

MODELO	CAP.KG	L. CABLE INOX	PESO	USO
LIGHT 4	2 - 4	2,5 m	2,1	Intenso
LIGHT 6	4 - 6		2,1	
LIGHT 8	6 - 8		2,5	
LIGHT 10	8 - 10		3,7	
LIGHT 12	10 - 12		3,8	

MODELO	CAP.KG	L. CABLE INOX	PESO	USO
9357-E	14 - 18	2 m	6,5	Intenso
9358-E	18 - 22		6,5	
9359-E	22 - 25		6,6	
9364-E	25 - 30		11,5	
9365-E	30 - 35		11,8	
9366-E	35 - 45		12,4	
9367-E	45 - 55		12,7	
9368-E	55 - 65		13,6	
9369-E	65 - 75		14,5	
9370-E	75 - 90		17,3	
9371-E	90 - 105	18,0		

► Opcional bloqueo manual.



Equilibradores ATEX

MODELO	CAP.KG	L. CABLE INOX	PESO	USO
9311AX	0,4 - 1	1,6 m	0,6	Intenso
9312AX	1 - 2		0,6	
9313AX	2 - 3		0,7	









Equilibradores Atex







 Bajo pedido

MODELO	CAP.KG	L. CABLE INOX	PESO	USO
9320AX	1 - 2,5	2 m	2	Intenso
9321AX	2 - 4		2	
9322AX	4 - 6		2,3	
9323AX	6 - 8		2,5	
9336AX	2 - 4	2,5 m	2,9	
9337AX	4 - 6		3,2	
9338AX	6 - 8		3,5	
9339AX	8 - 10		3,7	
9340AX	10 - 14		4	

Con bloqueo

MODELO	CAP.KG	L. CABLE INOX	PESO	USO
9346AX	2 - 4	2,5 m	2,9	Intenso
9347AX	4 - 6		3,2	
9348AX	6 - 8		3,5	
9349AX	8 - 10		3,7	
9350AX	10 - 14		4	

MODELO	CAP.KG	L. CABLE INOX	PESO	USO
9354AX 	4 - 7	2 m	4,94	Intenso
9355AX 	7 - 10		5,3	
9356AX 	10 - 14		6,8	
9357AX 	14 - 18		6,26	
9358AX 	18 - 22		6,39	
9359AX 	22 - 25		6,53	

MODELO	CAP.KG	L. CABLE INOX	PESO	USO
9520AX 	12 - 20	2,7 m	12,8	Intenso
9521AX 	20 - 30		12,6	
9522AX 	30 - 40		15,8	
9523AX 	40 - 50		15,4	
9524AX 	50 - 60		16,6	
9525AX 	60 - 70		15,7	





Atornilladores

TIPOS DE ATORNILLADOR SEGÚN EMBRAGUE

CONTROL DE PAR Y DESCONEXIÓN



- Cuando el atornillador alcanza el par prefijado, cierra el paso del aire y se detiene automáticamente.
- Son los atornilladores de mayor duración, ya que su desgaste es menor.
- Recomendado cuando se requiere un par de apriete preciso.
- Son los ideales para plásticos, chapas delgadas, materiales delicados y en la mayoría de las operaciones de montaje.

Par de apriete: rápido, preciso y estable

Ajuste exterior del par de forma sencilla

Menor consumo de aire

Menor reacción, ruido y vibración

Menor fatiga del operario

Menor desgaste del atornillador y de las puntas

POSITIVO



- Funcionamiento similar al de embrague deslizante.
- Actúa mediante un sistema de dos coronas almenadas, se gradúan haciendo girar el casquillo exterior.
- Recomendados en tornillos y materiales donde la resistencia sea variable y se deba sobrepasar el par.

DIRECTO

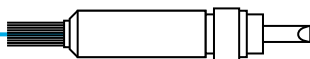

- Funcionan por ahogo del motor. Se pueden ajustar regulando la presión de entrada del aire y graduando la presión sobre el gatillo.
- El operario debe controlar visualmente la función de apriete, para evitar pasarse del par deseado.
- Recomendados en tornillos de madera autorroscante y autotaladrante, cuando no se puede usar los de embrague deslizante o positivo.

DESlizANTE

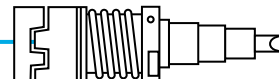

- Actúa mediante un sistema de muelle y bolas, que patinan al alcanzar el par de apriete prefijado.
- Tiene buena precisión de par, pero no tanto como los de control de par y desconexión.
- Es el sistema más versátil de atornillado, ya que sus características se adaptan a la mayoría de los tipos de tornillo.
- Recomendados para tornillos: rosca chapa, madera, autotaladrantes y los de rosca métrica.
- Pueden ser de regulación exterior o interior.
- Los de regulación exterior son los más cómodos y se gradúa el par haciendo girar el casquillo del embrague hasta el par deseado.
- Los de regulación interior, hay que desmontar la carcasa delantera y comprimir o descomprimir el muelle del embrague hasta conseguir el par deseado.
- Si se comprime el muelle en exceso, se puede anular la función del embrague.

Par de apriete: rápido, preciso y estable

Gran capacidad de par de apriete

Gran velocidad de apriete

Buen comportamiento en condiciones de apriete variable

IMPACTO



- Funcionan mediante dos martillos gemelos que golpean el eje, logrando un apriete más rápido y potente que los demás sistemas.
- Excelente relación peso / potencia y mínima reacción. Sistema muy utilizado para grandes uniones roscadas.
- Para regular el par de apriete, hay que ajustar el regulador de entrada de aire.



Atornilladores de impacto 1/4"

✓ Bajo pedido

GT-PLP

Reversible



6SSLD 1/4" • 6SSL 3/8"

Reversible

6SSLD 1/4" 6SSL 3/8"



8SSLD 1/4" • 8SSL 3/8"

Reversible

8SSLD 1/4" 8SSL 3/8"





MODELO	IMPAC.	CAPAC.	PAR NM	RPM	↔	KG	CONSUM.	MANG.	R	USO
GT-PLP ✓	Doble	M-5	7	9.000	197	0,7	200	8	1/4	Intenso
6SSL		M-6	18	8.000	202	1	300			Continuo
6SSLD		M-6	18	8.000	202	1	300			Continuo
8SSL		M-10	230	8.000	220	1,3	300			Continuo
8SSLD		M-10	230	8.000	220	1,3	300			Continuo



Atornilladores de impacto 1/4"

6SLD 1/4" • 6SL 3/8"



Reversible

 6SLD 1/4"
  6SL 3/8"



8SLD 1/4" • 8SL 3/8"

Reversible

 8SLD 1/4"
  8SL 3/8"



868AH

Reversible

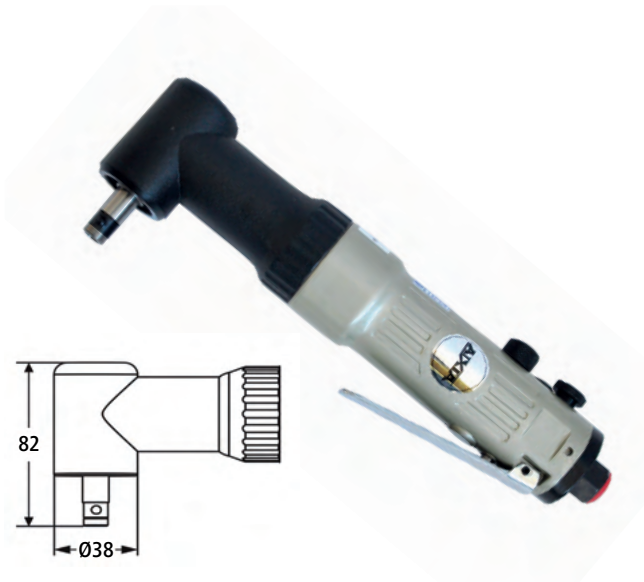

MODELO	IMPAC.	CAPAC.	PAR NM	RPM	↔	KG	CONSUM.	MANG.	R	USO
6SL	Doble	M-6	18	8.000	175	1,20	300	8	1/4	Continuo
6SLD		M-6	18	8.000	175	1,20				Continuo
8SL		M-10	270	8.500	155	1,30				Continuo
8SLD		M-10	270	8.500	155	1,30				Continuo
868AH		M-8	17	6.500	260	1,20				Continuo



Atornilladores con desconexión 1/4"

✓ Bajo pedido



ST-44000 • ST-44002
ST-44004 • ST-44006 • ST-44008

Accionamiento por contacto

- ▶ Embrague de desconexión y regulación exterior.
- ▶ Puesta en marcha presionando la punta sobre el tornillo a introducir.
- ▶ Reversibles, bien invirtiendo el sentido del selector, bien presionando la palanca.



ST-44004L • ST-44008L

Accionamiento por palanca



GT-S4TR



MODELO	REGUL.	CAPAC.	PAR NM	RPM	↔	KG	CONSUM.	MANG.	R	USO
ST-44000	Exterior	M 1,7 - 3,3	0,1 - 1,0	1.000	180	0,50	250	8	1/4	Intenso
GT-S4TR ✓		M 2,4 - 4	0,3 - 2,1		210	0,60	280	6		Intenso
ST-44002		M 2,6 - 5	0,4 - 3,3		180	0,50	280	8		Intenso
ST-44004		M 2,9 - 6,4	0,7 - 6,5	245	0,80	550	Intenso			
ST-44006		M 4,1 - 7,2	1,5 - 10				550			Intenso
ST-44008		M 5 - 9,3	3,0 - 18	300	Intenso					
ST-44004L		M 2,9 - 6,4	0,7 - 6,5	1.000	Intenso					
ST-44008L		M 5 - 9,3	3,0 - 18	300	Intenso					



Atornilladores con desconexión 1/4"

S44002P



- Embrague de desconexión y regulación exterior.
- Puesta en marcha presionando la punta sobre el tornillo a introducir.
- Reversibles invirtiendo el sentido del selector.

S44004P • S44006P • S44008P



Entrada de aire superior e inferior

- Embrague de desconexión y regulación exterior.
- Puesta en marcha presionando la punta sobre el tornillo a introducir.
- Reversibles invirtiendo el sentido del selector.

MODELO	REGUL.	CAPAC.	PAR NM	RPM	↔	KG	CONSUM.	MANG.	R	USO
S44002P	Exterior	M 2,8 - 5	0,5 - 3,5	1.000	178	0,65	360	8	1/4	Intenso
S44004P		M 3,5 - 6,6	1,2 - 7,5	1.000	215	1	500			Intenso
S44006P		M 5 - 7,3	3 - 11	550	215	1	500			Intenso
S44008P		M 5 - 9,3	3 - 18	300	215	1	500			Intenso



Atornilladores con desconexión eléctrica 1/4"

412L/C • 630L/C

- Diseñados para uso en métricas de Ø pequeños en placas electrónicas, óptica o similares.
- Accionamiento por gatillo.
- Con protección antidescargas electrostáticas.
- Transformador incluido en el precio de la maquina.



SP-32HL60T/C6



- Transformador para atornillador
- Posibilidad de 2 regulaciones de revoluciones
- Incluido de serie con 412L/C y 630L/C

EAA-AH1 • EAA-AH2

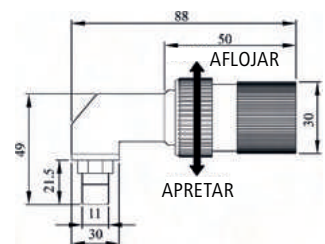
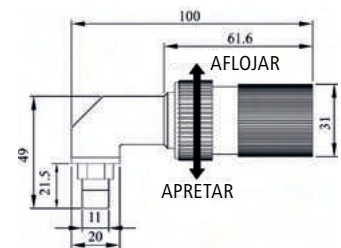

MODELO	REGUL.	CAPAC.	PAR NM	RPM	↔	KG	VOLTAJE		USO
							ENTRADA	SALIDA	
412L/C	Exterior	M 1,6 - 3,0	0,1 - 1,18	600-1000	230	0,48	220 V	32 V	Intenso
630L/C		M 3,0 - 5,0	0,78 - 2,94	300-500	260	0,60	220 V	32 V	Intenso
EAA-AH1				Codo para 630L/C					
EAA-AH2				Codo para 412L/C					
SP-32HL60T/C6				Transformador					



Atornilladores de embrague y directo 1/4"

CS-48 • CS-58



- Con embrague deslizante y regulación exterior.

862 • 863



- Con embrague deslizante y regulación exterior.

822 • 823

- Con embrague deslizante y regulación exterior.



SD-400

- Accionamiento directo. Sin embrague.



MODELO	EMBRA.	REGUL.	CAPAC.	PARA NM	RPM	↔	KG	CONSUM.	MANG.	USO	
CS-48	Deslizante	Exterior	M 3 - 6	1 - 6	1.700	206	0,84	500	8	Intenso	
CS-58			M 3 - 8	1 - 9	750	206	0,84			Intenso	
862	Positivo		M 3 - 6	3 - 8	1.800	240	1,1	300		Continuo	
863			M 3 - 8	4 - 11	800	255	1,2			Continuo	
822	Deslizante		M 3 - 6	3 - 8	1.800	240	1,1			300	Continuo
823			M 3 - 8	4 - 11	800	255	1,2				Continuo
SD400	Directo	No tiene	M 3 - 8	8 - 11	400	160	1,2		Continuo		



Atornilladores de embrague 1/4"

404-A • 404-8



- Con embrague deslizante y regulación interior.

CCP-48 • CCP-58



- Con embrague deslizante y regulación exterior.

810T



- Con embrague positivo y regulación exterior.

852 • 853



- Con embrague positivo y regulación exterior.

842 • 843



- Con embrague deslizante y regulación exterior.

MODELO	EMBRA.	REGUL.	CAPAC.	PARA NM	RPM	↔	KG	CONSUM.	MANG.	USO
404-A	Deslizante	Interior	M 3 - 6	3 - 8	1.800	205	1,2	300	8	Ocasional
404-8			M 3 - 8	4 - 11	800	216	1,3			Ocasional
CCP-48		Exterior	M 3 - 6	1 - 6	1.700	165	0,85	500		Intenso
CCP-58			M 3 - 8	1 - 9	750	165	0,85			Intenso
842	Positivo	Exterior	M 3 - 6	3 - 8	1.800	203	1,2	300	Continuo	
843			M 3 - 8	4 - 11	800	216	1,3		Continuo	
852			M 3 - 6	3 - 8	1.800	203	1,2		Continuo	
853		Interior	M 3 - 8	4 - 11	800	216	1,3	Continuo		
810T			M 3 - 8	3 - 10	1.800	205	1,3	Continuo		



Taladros

600AH

Reversible. Carcasa composite



500AH/K



T1003C

Carcasa composite



226S



523DS/K



MODELO	CAPAC.	PORTABROC.	POTENCIA	RPM	↔	KG	CONSUM.	MANG.	R	USO
600AH	10	Llave	300 W	1.200	214	1,2	300	8	1/4	Continuo
500AH/K		Llave		1.900	188	0,9				Continuo
T1003C		Rápido		2.500	215	1,04				Continuo
226S		Rápido		2.600	203	0,9				Ocasional
523DS/K		Rápido		3.800	190	1,1				Continuo



Taladros

232P

Reversible



- Puede utilizarse para trabajos puntuales de atornillado.

250RP

Reversible



- Puede utilizarse para trabajos puntuales de atornillado.

260P

- Puede utilizarse para trabajos puntuales de atornillado.

MODELO	CAPAC.	PORTABROC.	POTENCIA	RPM	↔	KG	CONSUM.	MANG.	R	USO
232P	10	Rápido	300 W	1.800	170	1,4	300	8	1/4	Continuo
250RP	10	Rápido		2.000	170	1,1	300	8		Ocasional
260P	10	Llave		1.800	170	1,1	200	10		Ocasional



Taladros

540P

Reversible



- En composite, menor peso y con gatillo progresivo para el control de la velocidad de accionado.

520P/K



748P



MODELO	CAPAC.	PORTABROC.	POTENCIA	RPM	↔	KG	CONSUM.	MANG.	R	USO
540P	10	Rápido	300 W	2.000	195	1,0	113	10	1/4	Continuo
520P/K	10			2.200	165	1,0	300	8		Continuo
748P	8			4.500	160	1,1	300	8		Ocasional



Taladros

HDD-48

Reversible



- Puede utilizarse para trabajos puntuales de atornillado.

HDD-458

Reversible



- Puede utilizarse para trabajos puntuales de atornillado.

443PT

Taladro percutor

SA705803BK

- Consultar composición y precios del kit

MODELO	CAPAC.	PORTABROC.	POTENCIA	RPM	↔	KG	CONSUM.	MANG.	R	USO
HDD-48	10	Rápido	360 W	1.700	199	0,9	400	8	1/4	Intenso
HDD-458	13	Rápido	360 W	750	199	0,9	350	8	1/4	Intenso
443PT	10	Llave	300 W	7.000	225	2,6	400	8	1/4	Continuo
SA705803BK	Maletín con brocas y puntas para taladro y atornillador									



Taladros

233P



Reversible

- Puede utilizarse para trabajos puntuales de atornillado.

PORTABROCAS PLÁSTICO



MODELO	CAPAC.	ROS.
800-0-10P	1 - 10	3/8 - 24
800-2-13P	1,5 - 13	

550P



Reversible

- Puede utilizarse para trabajos puntuales de atornillado.
- En composite, menor peso y con gatillo progresivo para el control de la velocidad de accionado.

PORTABROCAS LLAVE



MODELO	CAPAC.	ROS.
400S-2	1 - 10	3/8 - 24
400S-3	1 - 13	

530R/K



Reversible

- Puede utilizarse para trabajos puntuales de atornillado.

PORTABROCAS METÁLICO



MODELO	CAPAC.	ROS.
800-1-10	1 - 10	3/8 - 24
800-2-13	1,5 - 13	

MODELO	CAPAC.	PORTABROC.	POTENCIA	RPM	↔	KG	CONSUM.	MANG.	R	USO
233P	13	Rápido	300 W	800	195	1,8	350	8	1/4	Continuo
550P			360 W	800	219	1,3	113	10		Intenso
530R/K			300 W	500	185	1,6	400	8		Intenso



Taladros

FRD-6S

FCD-6B-1F

TA-0306

- Cabezal compacto de 26 mm de altura
- Admite broca roscada de 1/4-28UNF y puede dotarse de portabrocas opcional de 3, 4, 5 y 6 mm

FRD-6PH-3

FRD-6PH-5 • FRD-6PH-7

MODELO	TIPO	CAPAC.	POTENCIA	RPM	↔	KG	CONSUM.	MANG.	R	USO
FRD-6S-2F	Recto	6	320 W	4.300	208	0,9	340	8	1/4	Intenso
FRD-6S-3F		8		2.800	208	0,9				Intenso
FRD-6S-5F		10		1.300	227	1,1				Intenso
FRD-6S-7F		13		600	262	1,6		10		Intenso
FRD-6PH-3	Pistola	8	320 W	2.800	164	1,1	340	8	1/4	Intenso
FRD-6PH-5		10		1.300	187	1,3		10		Intenso
FRD-6PH-7		13		600	222	1,7		10		Intenso
FCD-6B-1F	Acodado	6	160 W	2.500	222	0,6	280	6		Intenso
TA-0306	Acodado	6	300 W	3.200	256	0,65	368	10	1/4	Intenso



Taladros

4250

Reversible



FRD-16Z-1C

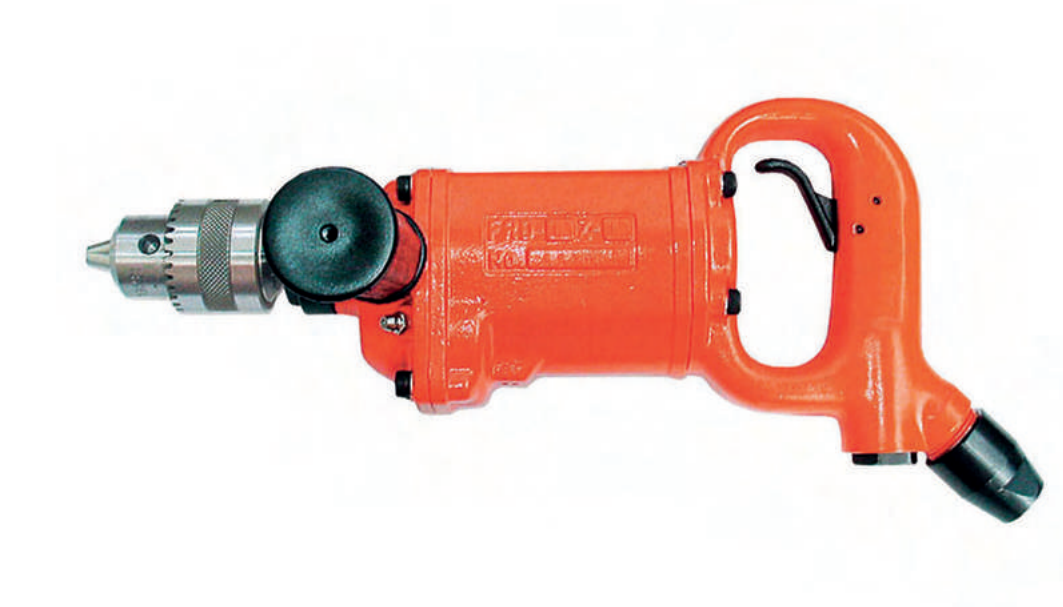

MODELO	TIPO	CAPAC.	POTENC.	RPM	↔	KG	CONSUM.	MANG.	R	USO
4250	Recto	16	700 W	1000	420	6,3	1.000	13	3/8	Intenso
FRD-16Z-1C	Recto	16	700 W	800	332	3,4	1.000	13	3/8	Intenso



Taladros

FCD-23R-12S • FCD-32R-11S • FCD-50R-11S



FRD-23R-22S • FRD-32R-11S • FRD-50R-11S

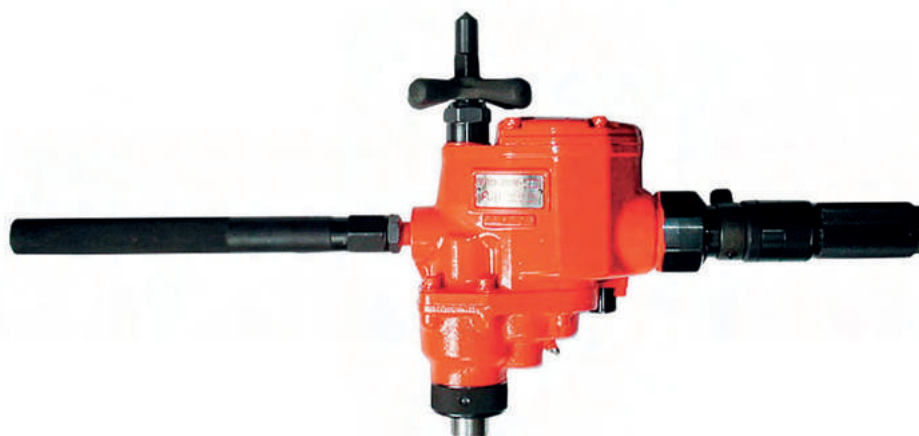

MODELO	TIPO	CAPAC.	POTENC.	RPM	↔	KG	CONSUM.	MANG.	R	USO
FRD-23R-22S	Vertical	23	850 W	480	282	7,4	1.200	13	1/2	Intenso
FRD-32R-11S		32	1.800 W	380	353	13,0	2.600	19	1/2	Intenso
FRD-50R-11S		50	1.800 W	150	446	18,0	2.600	19	1/2	Intenso
FCD-23R-12S	Acodado	23	900 W	430	472	7,0	1.200	13	1/2	Intenso
FCD-32R-11S		32	1.600 W	350	578	13,5	1.800	19	1/2	Intenso
FCD-50R-11S		50	1.600 W	150	595	16,0	1.800	19	1/2	Intenso



Roscadoras



Todos los modelos con cabezales de roscado articulados que mejoran la productividad en todos los sectores facilitando el correcto guiado del macho.

FT-6BX-1



FT-8PX-1



120

Con inversión de giro por tracción (push-pull)



MODELO	ACERO	ALUMINIO	POTENCIA	EJE	RPM	↔	KG	CONSUM.	MANG.	USO
FT-6BX-1	6	8	300 W	JT.1	2.000	240	1,5	400	8	Intenso
FT-8PX-1	8	10	400 W	MT.2	450	232	2,0	400		Intenso
120	12	12	300 W	MT.2	360 der - 720 iz	350	1,5	450		Intenso



Roscadoras y motores

120D

Con inversión de giro por tracción (push-pull)



MODELO	ACERO	ALUMINIO	POTENCIA	EJE	RPM	↔	KG	CONSUM.	MANG.	USO
120D	12	12	300 W	MT.2	360 der - 720 iz	350	1,5	450	8	Intenso

F-5SM-2R • F-6SM



MODELO	PAR NM	POTENCIA	Ø EJE	RPM	↔	KG	CONSUM.	MANG.	R	USO
F-5SM-2R	21,6	150 W	7	190	180	0,8	280	8	1/8	Intenso
F-6SM-28R	3,3	250 W	8,5	2.300	146	0,8	340	10		Intenso
F-6SM-21R	4,0	250 W	8,5	2.000	146	0,9	340			Intenso
F-6SM-12R	5,9	230 W	8,5	1.000	157	0,9	340			Intenso
F-6SM-5R	14,7	220 W	8,5	500	179	1,1	340			Intenso
F-6SM-2,5R	26,0	210 W	8,5	250	192	1,2	340			Intenso



Remachadoras

AR-5



- Recomendada para trabajos de mantenimiento general.

AR-6



- Recomendada para trabajos de mantenimiento general.

AR-10V

Trabaja tanto en horizontal como en vertical
Con succionador de vástagos



RAC-230



MODELO	CAPACIDAD		DOTACIÓN BOQUILLAS	↔	KG	CARRERA (MM)	POTENCIA TRACCIÓN	MANG.	USO
	INOX	ALUM							
AR-5	4		2,4 - 3,2 - 4 - 4,8	273	1,5	14	7.100	8	Ocasional
AR-6	4	4,8	2,4 - 3,2 - 4 - 4,8	260	1,5	15	9.810	8	Continuo
AR-10V	4,8		3,2 - 4 - 4,8	396	1,5	16	8.915	8	Continuo
RAC-230	4,8	4,8	2,4 - 3,2 - 4 - 4,8	443	1,66	15.5	8.709	8	Intenso



Remachadoras

AR-6PK

Presentado en estuche



AR-6PKV

Presentado en estuche
Con succionador de vástagos



AR-800PK

Presentado en estuche



AR-800PKV

Presentado en estuche
Con succionador de vástagos



MODELO	CAPACIDAD		DOTACIÓN BOQUILLAS	↔	KG	CARRERA (MM)	POTENCIA TRACCIÓN	MANG.	USO
	INOX	ALUM							
AR-6PK	4,8	4,8	3,2 - 4 - 4,8	290	1,3	18	10.785	8	Continuo
AR-6PKV	4,8	4,8	3,2 - 4 - 4,8	290	1,3	18	10.785	8	Continuo
AR-800PK	6,4	6,4	3,2 - 4 - 4,8 - 6,4	335	1,6	19	15.700	8	Continuo
AR-800PKV	6,4	6,4	3,2 - 4 - 4,8 - 6,4	335	1,6	19	15.700	8	Continuo



Remachadoras

RAC 83/95



- Herramienta de altas prestaciones para trabajos intensos asegurando su productividad.

RAC 83/AX

Con succionador de vástagos



- Herramienta de altas prestaciones para trabajos intensos asegurando su productividad.

MODELO	CAPACIDAD		DOTACIÓN BOQUILLAS	↔	KG	CONSUM.	POTENCIA TRACCIÓN	USO
	INOX	ALUM						
RAC 83/95	4	4,8	2,4 - 3 - 3,2 - 3,4 - 4 - 4,8	360	1,74	200	5.372	Intenso
RAC 83/AX	4	4,8	2,4 - 3 - 3,2 - 3,4 - 4 - 4,8	220	1,5	200	5.372	Intenso



Remachadoras

RAC-182

Con succionador de vástagos



- Herramienta de altas prestaciones para trabajos intensos asegurando su productividad.

AR-25V

Con succionador de vástagos



OPCIONAL:

Para remache Monobolt solicitar las referencias:

- RAR25V500014AV (boquilla monobolt 3/16)
- RAR25V500015AV (boquilla monobolt 1/4)

RAC-171

Con succionador de vástagos



- Herramienta de altas prestaciones para trabajos intensos asegurando su productividad.

MODELO	CAPACIDAD		DOTACIÓN BOQUILLAS	↔	KG	CARRERA (MM)	POTENCIA TRACCIÓN	MANG.	USO
	INOX	ALUM							
AR-25V	6,3	6,3	3,2 - 4 - 4,8 - 6,3 - 7	287	2,3	21	16.650	8	Continuo
RAC-182	5	6	2,4 - 3,2 - 4 - 4,8 - 6	302	2	20,5	10.500	8	Intenso
RAC-171	6,4	7,8	4,8 - 6 - 6,4 - 7,8	340	2,8	25,5	17.273	8	Intenso
			1/4 - 5/16 Monobolt y Huck						



Remachadoras de insertos

► En material composite, con lo que se reduce el peso y se consigue un mejor aislamiento térmico.

► Para tuercas remachables en aluminio, acero e inox.

RI-08PK • RI-12PK

Presentado en estuche



M312K

Presentado en estuche



KJ-60

• Herramienta de altas prestaciones para trabajos intensos asegurando su productividad.



KJ-45S

Presentado en estuche



• Herramienta de altas prestaciones para trabajos intensos asegurando su productividad.

• KJ-45S. Como opción, boquillas para tuercas remachables macho.

MODELO	CAPACIDAD		DOTACIÓN TIRANTES/BOQUILLAS	↔	KG	CONSUM.	POTENCIA TRACCIÓN	USO
	INOX	ALUM						
RI-08PK	M8	M8	M3, M4, M5, M6, M8	260	2,2	110	18.630	Intenso
RI-12PK	M10	M12	M4, M5, M6, M8, M10, M12	260	2,4	150	20.600	Intenso
M312K	M8	M12	M3, M4, M5, M6, M8, M10, M12	285	2,47	120	19.000	Continuo
KJ-60	M8	M8	M3, M4, M5, M6, M8	288	2,1	110	13.650	Intenso
KJ-45S	M12	M12	M4, M5, M6, M8, M10, M12	322	2,9	150	27.440	Intenso



Remachadoras manuales

K25

K33F

Para remache estructural

K39

Kit remachadora + remaches



MODELO	CAPACIDAD		DOTACIÓN BOQUILLAS	↔	KG	Ø BOQUILLA	R	USO
	INOX	ALUM						
K25	4,8	7,8	2,4 - 3 - 3,2 - 3,4 - 4 - 4,8 - 6 - 6,4 - 7,8	420	1,5	24 mm	1/4	Intenso
K33F	6,4	6,4	4,8 - 6,4	480/540	1,7	24 mm	1/4	Intenso
K39	4,8	4,8	2,4 - 3 - 3,2 - 3,4 - 4 - 4,8	275	0,55	22 mm		Intenso



Máquinas para abrasión

04



Lijadoras	122
Pulidoras	130
Platos, lijas y soportes	131
Amoladoras y lápiz grabador	134
Amoladoras de pinza	135
Amoladoras de muela	146
Desbarbadoras	148



Lijadoras rotorbitales sin aspiración

► Modelos 906-2, 906-5, 907-5, 910: en material composite reduciendo peso y vibraciones, y con un mayor aislamiento térmico. Con órbitas de 5 y 2,5 mm para trabajos de acabado fino o muy fino.

903V-3



906-2 • 906-5



907-5



910

Sin aceite



L50AHP



- Con plato de Ø 50 mm, para trabajos en espacios reducidos.

MODELO	Ø DISCO	ROSCA EJE	ÓRBITA	RPM	KG	CONSUMO	MANG.	R	USO
903V-3	77	M 6	2,5	15.000	0,9	190	8	1/4	Intenso
906-2	150	5/16	2,5	10.000	0,7	450	10		Intenso
906-5			5	10.000	0,7				Intenso
907-5			5	11.000	0,8				Intenso
910			5	11.000	0,8				Continuo
L50AHP			50	No	No				16.000



Lijadoras rotorbitales con aspiración

► Modelos 713, 906D-2, 906D-5, 931D-5, 907D-5, 908D-5, 910D: en material compuesto, reduciendo peso y vibraciones y con un mayor aislamiento térmico. Con órbitas de 5 y 2,5 mm para trabajos de acabado fino o muy fino.

► Los modelos con aspiración equipan boquilla de Ø 29 para su conexión.

713



906D-2 • 906D-5



907D-5



908D-5



910D

Sin aceite



MODELO	Ø DISCO	ROSCA EJE	ÓRBITA	RPM	KG	CONSUMO	MANG.	R	USO
713	75	5/16	2,5	11.000	0,8	450	10	1/4	Intenso
906D-2	150			10.000					Intenso
906D-5			5	10.000					Intenso
907D-5				11.000					Intenso
908D-5				10.000					Ocasional
910D			11.000	0,8					450



Lijadoras rotorbitales sin aspiración

764



915

Sistema autoaspirante



- Material composite reduciendo peso y vibraciones y con un mayor aislamiento térmico.
- Con órbitas de 5 y 2,5 mm para trabajos de acabado fino o muy fino.

905B1/K



905A



MODELO	Ø DISCO	ROSCA EJE	ÓRBITA	RPM	KG	CONSUMO	MANG.	R	USO
915	150	5/16	5	10.000	1	400	10	1/4	Intenso
764			10	10.000	1,3	300			Ocasional
905B1/K			10	10.000	1,3	400			Continuo
905A	150	5/16	10	10.000	1,4	400	10	1/4	Intenso



Lijadoras rotorbitales con aspiración

► Los modelos con aspiración equipan boquilla de Ø 29 para su conexión.

907D-10

► Modelo en material composite reduciendo peso y vibraciones y con un mayor aislamiento térmico. Con órbitas de 5 y 2,5 mm para trabajos de acabado fino o muy fino.



905AD

Sistema autoaspirante



INCLUYE:
• Bolsa y tubo aspiración.

905B4D6

Sistema autoaspirante



INCLUYE:
• Bolsa y tubo aspiración.

MODELO	Ø DISCO	ROSCA EJE	ÓRBITA	RPM	KG	CONSUMO	MANG.	R	USO
915D	150	5/16	5	10.000	1	400	10	1/4	Intenso
907D-10			10	11.000	0,8	450			Intenso
905AD			10	10.000	1,6	400			Intenso
905B4D6			10	10.000	1,7	400			Intenso



Lijadoras orbitales sin aspiración

813V



821D



815



MODELO	BASE	ÓRBITA	RPM	KG	CONSUM.	MANG.	R	USO
813V	70 x 100 Triangular Velcro	5	10.000	0,7	300	10	1/4	Intenso
821D	75 x 100 Velcro	3	12.000	1	120			Continuo
815	74 x 145 Adhesiva + Pinzas	5	8.000	1,2	350			Intenso



Lijadoras orbitales sin aspiración

873BL-L



774B



MODELO	BASE		ÓRBITA	RPM	KG	CONSUM.	MANG.	R	USO
873BL-L	74 x 155	Adhesiva + Pinzas	5	9.000	0,9	266	10	1/4	Intenso
774B	73 x 140	Adhesiva + Pinzas		8.000	1,5	250			Intenso



Lijadoras rotorbitales con aspiración

► Los modelos con aspiración equipan boquilla de Ø 29 para su conexión.

774BD

Sistema autoaspirante



812BDV1

Sistema autoaspirante

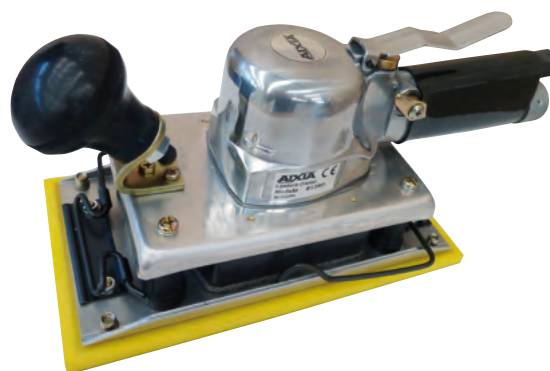

MODELO	BASE		ORIFICIOS	ÓRBITA	RPM	KG	CONSUM.	MANG.	USO
774BD	74 x 145	Adhesiva + Pinzas	6	5	8.000	1,3	350	10	Intenso
812BDV1	115 x 222	Velcro + Pinzas	10	5	6.000	2,6	400		Intenso



Lijadoras de banda

► Modelos 212A y 220A: idóneas para uso intenso en metales duros con altas exigencias de acabado.

► La longitud de su cabezal nos permite trabajar en zonas estrechas o de difícil acceso.

7009



212A



7010



220A



MODELO	BASE	TIPO	RPM	KG	CONSUMO	MANGUERA	R	USO
7009	10 x 330		16.000	0,9	350	8	1/4	Continuo
212A	12 x 330	Con regulador de velocidad	13.000	0,9	350			Intenso
7010	20 x 520		16.000	1,1	400			Continuo
220A	20 x 520	Con regulador de velocidad	12.000	1,4	400			Intenso



Lijadoras

222SD/K

230/K

Incluye disco 670G

231/K

Incluye disco 670G



MODELO	Ø DISCO	ROSCA EJE	RPM	KG	CONSUMO	MANGUERA	R	USO
222SD/K	125	1/4	16.000	1	300	10	1/4	Ocasional
230/K	180	5/8	5.000	1,8	400	10		Ocasional
231/K		5/8	4.500	1,8	400	10		Continuo



Pulidoras

203P

Puede usar discos de 50mm y 75mm



COMPOSICIÓN
DEL MALETÍN:
2158, 2159,
4181, 6603V3P



205P



- Puede usar discos de 75 y 125 mm

241/K



- Puede usar discos de 125, 150 y 180 mm
- Incluye disco 670G

MODELO	Ø DISCO	ROSCA EJE	RPM	KG	CONSUMO	MANGUERA	R	USO
203P	75	M 6	2.500	0,9	190	8	1/4	Continuo
205P	125	5/16	2.000	1	300	8		Continuo
241/K	180	5/8	2.200	1,8	400	10		Continuo



Platos y soportes

PARA HERRAMIENTAS:
903V-3 • 203P



MOD.	Ø DISCO	EJE	TIPO
6003V2P	50	M6	Velcro
6603V3P	75		Velcro

PARA HERRAMIENTAS:
906D • 907D • 905AD
905BD • 910D • 915D
931D-5

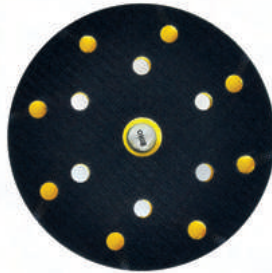

MODELO	Ø DISCO	EJE	TIPO
6686-14	150	5/16	Velcro

PARA HERRAMIENTAS:
764 • 905A • 905B1/K
906-2 • 906-5 • 907-5 • 205P
910 • 915 • 905B4D6



MODELO	Ø DISCO	EJE	TIPO
6685	125	5/16	Velcro
6686	150		Velcro
6636	150		Adhes.

PARA HERRAMIENTAS:
205P • L50AHP • 713



MODELO	Ø DISCO	EJE	TIPO
3686	75	5/16	Velcro
2686	50	5/16	Velcro

PARA HERRAMIENTAS:
713



MODELO	Ø DISCO	EJE	TIPO
3686-3	75	5/16	Velcro

PARA HERRAMIENTAS:
906D • 907D • 905AD
905BD • 910D • 915D
931D • 905B4D6



GRE
(Grueso)

PARA HERRAMIENTAS:
222SD/K



MODELO	Ø DISCO	TIPO
4405	125	Fibra Flexible

MODELO	Ø DISCO	EJE	TIPO	AGUJ
6686-6	150	5/16	Velcro	6
6636-6	150		Adhes.	
6686-6 GRE	150		Velcro	



Lijas y soportes

80VP

Para Herramientas:
903V-3 • 203P



MODELO	TIPO
80VP060	Velcro
80VP080	
80VP120	
80VP180	
80VP280	
80VP400	
80VP600	

Paquetes de 50 unidades

TV70X100

Para Herramientas:
813V



MODELO	TIPO
TV70X100 G.60	Velcro
TV70X100 G.80	
TV70X100 G.120	
TV70X100 G.180	
TV70X100 G.280	

Paquetes de 50 unidades

RP-7

Para Herramientas:
BG-7 • BG-7C • BG-7CMT
BG-180 • FA-6C-6M



MODELO	Ø DISCO
RP-7	178

Soporte de goma

RP-5-6

Para Herramientas:
BG-125P • BG-125PMT
FA-5E-2F • BG-5



MODELO	Ø DISCO
RP-5-6	127

Soporte de goma

BANDAS DE LIJA



MODELO	MEDIDA	PARA	GRANO
330x10 G-60	330 x 10	7009 y 212A	60
330x10 G-80			80
330x10 G-120			120
520x20 G-60	520 x 20	7010 y 220A	60
520x20 G-80			80
520x20 G-120			120

Paquetes de 50 unidades



Platos y soportes

Con Herramientas:
230/K • 231/K • 241/K



MODELO	Ø DISCO	EJE	TIPO
4203	150	5/8	Velcro
4207	180	5/8	
4203M14	150	M14	
4203/125	125	5/8	
4203M14/125	125	M14	

670-G

Con Herramientas:
230/K • 231/K • 241/K



MODELO	Ø DISCO	EJE	TIPO
670-G	180	5/8	Rígido

Con Herramientas:
205P • 241/K



MODELO	Ø DISCO	FIJAC.	TIPO
4187	125	Velcro	B.Lana
4189	150	Velcro	
4180	180	Velcro	

4164

Con Herramientas:
241/K • 205P



MODELO	Ø DISCO	FIJAC.	TIPO
4164	150	Velcro	Fino

4181

Con Herramientas:
203P • 205P



MODELO	Ø DISCO	FIJAC.	TIPO
4181	75	Velcro	B.Lana

2158

Con Herramientas:
203P



MODELO	Ø DISCO	FIJAC.	TIPO
2158	90	Velcro	Duro

2159

Con Herramientas:
203P

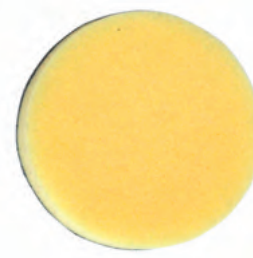

MODELO	Ø DIS.	FIJAC.	TIPO
2159	90	Velcro	Semiduro

Lápiz grabador y amoladoras de pinza

909



254



MIS



MA-260



GT-MG55SR



MODELO	DESCRIPCIÓN			RPM	↔	KG	CONSUM.	MANG.	R	USO
909	Lápiz grabador			10.000	170	0,2	80	6	1/4	Continuo
MODELO	PINZA	CAPAC.	POTENC.	RPM	↔	KG	CONSUM.	MANG.	R	USO
MA-260	3	13	105 W	60.000	132	0,13	250	6	1/4	Continuo
254	3	13	105 W	54.000	132	0,2	160	6		Continuo
GT-MG55SR	3	13	105 W	55.000	180	0,2	160	6	1/4	Intenso
MIS	3	10	75 W	60.000	170	0,15	150	6		Intenso



Amoladoras de pinza

✓ Bajo pedido

MA-272

GT-MG35-12CC

FA-20-2F

200AH

MODELO	PINZA	CAPAC.	POTENC.	RPM	↔	KG	CONSUM.	MANG.	R	USO
MA-272	3	5	105 W	72.000	132	0,25	250	6	1/4	Continuo
GT-MG35-12CC ✓	3	13	105 W	35.000	150	0,2	160	6	1/4	Intenso
200AH	6	25	300 W	20.000	120	0,6	250	8	1/4	Continuo
FA-20-2F	6	50	300 W	15.000	186	0,7	500	10	1/4	Intenso

► Consultar pinza Ø 8 mm.



Amoladoras de pinza

2011AHP90



NG-50AH



2011AHP



2011AHPK



MODELO	PINZA	CAPAC.	POTENC.	RPM	<-->	KG	CONSUM.	MANG.	R	USO
2011AHP	6	25	300 W	18.000	180	0,7	250	8	1/4	Continuo
2011AHP90		25	300 W	20.000	156	0,6	250	8		Continuo
NG-50AH		50	260 W	15.000	166	0,76	400	10		Continuo
2011AHPK		25	300 W	18.000	180	0,7	250	8		Continuo

► Consultar pinza Ø 8 mm. ► La pinza de Ø 3 es opcional en todos los modelos.



Amoladoras de pinza

2011AHP125

Con salida trasera



5252AHP

Con salida trasera



2012AHPB



- Cuerpo composite reduciendo peso y con un mayor aislamiento térmico.
- Regulador de velocidad y bloqueo del eje por botón facilitando el cambio de útil con una sola llave.

SOPORTE DE GOMA



P7735-A05M
Soporte de goma 2"

P7735-A06M
Soporte de goma 3"

MODELO	PINZA	CAPAC.	POTENC.	RPM	↔	KG	CONSUM.	MANG.	R	USO
2011AHP125	6	25	300 W	18.000	194	0,6	250	8	1/4	Continuo
2012AHPB		30	375 W	20.000	193	0,9	600	10		Continuo
5252AHP		65	735 W	12.000	212	1,2	450	10		Continuo

► Consultar pinza Ø 8 mm. ► La pinza de Ø 3 es opcional en todos los modelos.



Amoladoras de pinza

202A

Con salida trasera



203



200



2011



MODELO	PINZA	CAPAC.	POTENC.	RPM	↔	KG	CONSUM.	MANG.	R	USO
202A	6	25	224 W	25.000	115	0,29	283	10	1/4	Continuo
203		25	275 W	21.000	176	0,52	400	8		Ocasional
200		25	300 W	25.000	120	0,4	250	8		Continuo
2011		25	300 W	20.000	146	0,6	300	8		Continuo

► La pinza de Ø 3 es opcional en todos los modelos.



Amoladoras de pinza

2011A

Con salida trasera

A1006L

Con salida trasera

218

Con salida trasera

127PK

Con pinzas de 3 y 6 mm



MODELO	PINZA	CAPAC.	POTENC.	RPM	↔	KG	CONSUM.	MANG.	R	USO
2011A	6	25	300 W	25.000	156	0,6	300	8	1/4	Continuo
A1006L	6	25	400 W	22.000	170	0,7	368			Continuo
218	6	40	670 W	18.000	185	0,6	400			Continuo
127PK	3 y 6	25	300 W	20.000	146	0,6	300			Ocasional

► La pinza de Ø 3 es opcional en todos los modelos.



Amoladoras de pinza

A1046L



523

Con salida trasera



5052

Con salida trasera



MODELO	PINZA	CAPAC.	POTENC.	RPM	↔	KG	CONSUM.	MANG.	R	USO
A1046L	6	50	400 W	3.500	210	0,95	368	10	1/4	Continuo
523		50	400 W	4.000	190	0,8	350			Continuo
5052		65	735 W	22.000	200	0,8	450			Continuo

► La pinza de Ø 3 es opcional en todos los modelos.



Amoladoras de pinza

2012B

Con salida trasera



- Con sistema de bloqueo del eje que facilita el cambio del útil.
- La pinza de Ø 3 es opcional.

2012



NG-24 • NG-30



NG-40



MODELO	PINZA	CAPAC.	POTENC.	RPM	↔	KG	CONSUM.	MANG.	R	USO
2012B	6	25	261 W	25.000	185	0,54	370	13	1/4	Continuo
NG-24		25	300 W	24.000	171	0,6	350	8		Continuo
NG-40		50	300 W	24.000	172	0,6	400	10		Intenso
NG-30		50	350 W	18.000	176	0,85	430	10		Continuo
2012		65	550 W	23.000	175	0,8	370	10		Continuo

► La pinza de Ø 3 es opcional en todos los modelos.



Amoladoras de pinza

NG-45



FG-26H-10F



FG-50H-1F



FG-50D-1F



MODELO	PINZA	CAPAC.	POTENC.	RPM	↔	KG	CONSUM.	MANG.	R	USO
FG-26H-10F	6	25	275 W	24.000	179	0,53	580	10	1/4	Intenso
FG-50H-1F		50	350 W	18.000	191	0,8	430	10		Intenso
FG-50D-1F		50	350 W	18.000	210	0,9	450	10		Intenso
NG-45	6	50	350 W	20.000	165	0,8	400	10	1/4	Intenso



Amoladoras de pinza

2011AHPL



2011LP



NG-24L



A1006L-340



MODELO	PINZA	CAPAC.	POTENC.	RPM	↔	KG	CONSUM.	MANG.	R	USO
2011LP	6	25	300 W	20.000	282	0,8	300	8	1/4	Continuo
NG-24L			300 W	23.000	295	0,97	350	10		Continuo
2011AHPL			300 W	25.000	251	0,9	300	8		Continuo
A1006L-340			400 W	22.000	340	1,3	370	10		Continuo

► Consultar pinza Ø 8 mm.



Amoladoras de pinza

2012L



FG-26HL-10F

NG-65 • NG-75



MODELO	PINZA	CAPAC.	POTENC.	RPM	↔	KG	CONSUM.	MANG.	R	USO
FG-26HL-10F	6	25	300 W	24.000	273	0,7	350	8	1/4	Intenso
NG-65	6	65	500 W	16.000	360	1,2	500	10	3/8	Intenso
2012L		65	735 W	23.000	455	1,5	370	10	1/4	Continuo
NG-75		75	500 W	15.000	360	1,3	600	10	3/8	Intenso

► Consultar pinza Ø 8 mm.



Amoladoras de pinza

NG-80



NG-65L



NG-75L



NG-95L



MODELO	PINZA	CAPAC.	POTENC.	RPM	↔	KG	CONSUM.	MANG.	R	USO
NG-65L	6	65	500 W	16.000	425	1,3	500	10	3/8	Intenso
NG-95L		65	1.000 W	22.300	655	1,75	380	10		Intenso
NG-80		75	500 W	14.600	395	1,74	600	10		Continuo
NG-75L		75	500 W	15.000	570	2,5	600	10		Intenso

► Para uso de cepillo consultar. ► Consultar pinza Ø 8 mm.



Amoladoras de muela

NG-125



NG-150



FG-4H-2F



FG-6H-1M



MODELO	PINZA	Ø DISCO	CAPAC.	RPM	↔	KG	CONSUM.	MANG.	R	USO
NG-125	Opcional	125	1.000 W	7.200	390	3	1.200	13	1/2	Intenso
NG-150		150	1.100 W	6.000	445	4	1.200	13		Intenso
FG-4H-2F	Opcional	100	700 W	9.500	419	2	800	13	3/8	Intenso
FG-6H-1M		150	1.300 W	6.300	521	4,6	1.300	13		Intenso

► Para uso de cepillo consultar. ► Consultar pinza Ø 6 mm y Ø 8 mm.



Amoladoras de muela

FG-8H-1M

FG-3HL-1F

FG-5HL-2M

MODELO	PINZA	Ø DISCO	CAPAC.	RPM	↔	KG	CONSUM.	MANG.	R	USO
FG-3HL-1F	Opcional	65	500 W	12.000	547	1,8	500	10	3/8	Intenso
FG-5HL-2M		100	1.000 W	9.000	1050	5	1.000	13	3/8	Intenso
FG-8H-1M		205	1.500 W	4.600	556	5,5	1.600	13	1/2	Intenso

► Para uso de cepillo consultar. ► Consultar pinza Ø 6 mm y Ø 8 mm.



Desbarbadoras

BG-50

FA-20-1F

BG-4

BG-125P • BG-125PMT

MODELO	DISCO	EJE	POTENC.	RPM	↔	KG	CONSUM.	MANG.	R	USO
BG-50	50	1/4 - 28	300 W	15.000	166	0,75	400	10	1/4	Continuo
FA-20-1F	50 x 9,5	1/4 - 28	300 W	15.000	186	0,7	500	10	1/4	Intenso
BG-4	100 x 16	-	700 W	12.000	228	2	400	10	1/4	Continuo
BG-125P	125 x 22	5/8 - 11	700 W	10.000	230	1,9	400	10	1/4	Continuo
BG-125PMT		M14	700 W		230	1,9	400	10	1/4	Continuo



Desbarbadoras

BG-125BLMT



- Pulsador de bloqueo del cabezal para cambio del disco.

BG-5 • BG-5MT



FA-45-5F



FA-5E-2F



BG-125VA



- Protección con boquilla para aspiración Ø 27.

DISCOS CORTE / DESBASTE



DISCO FA-2C
Disco corte: 65x1x10

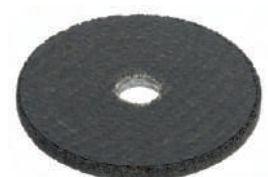

DISCO
Disco rebabar: 60x4x10

MODELO	DISCO	EJE	POTENC.	RPM	↔	KG	CONSUM.	MANG.	R	USO
BG-125BLMT	125 x 22	M14	700 W	11.000	238	2	600	13	1/4	Continuo
BG-5		M8 - P1,25	800 W	12.000	200	2	900	13	1/4	Intenso
BG-5MT		M14	800 W		200	2	900	13	1/4	Intenso
FA-45-5F	125 x 22	M14	1.000 W	12.000	259	2,1	1.140	10	3/8	Intenso
FA-5E-2F		M8 - P1,25	930 W		282	2,1	900	13	3/8	Intenso
BG-125VA	125	M14	950 W	11.000	232	1,8	540	10	1/4	Continuo



Desbarbadoras

BG-180



BG-7



BG-7CMT • BG-7C



FA-6C-6M



MODELO	DISCO	EJE	POTENC.	RPM	↔	KG	CONSUM.	MANG.	R	TIPO
BG-180	180 x 22	5/8- 11	1.300 W	7.000	273	2,4	1.100	13	3/8	Continuo
BG-7		M8	1.300 W	7.600	254	3,2	1.100			Intenso
BG-7C		5/8- 11	1.400 W	7.600	297	3,3	1.300			Intenso
BG-7CMT		M14	1.400 W	7.600	297	3,3	1.300			Intenso
FA-6C-6M	180 x 22	5/8- 11	1.400 W	8.400	353	3	1.100	13	3/8	Intenso

► Para uso de cepillo de copa consultar.



Desbarbadoras

FA-9C-4M

NAS-9BDS

FV-7-4M

FV-9BH-1M

MODELO	DISCO	EJE	POTENC.	RPM	↔	KG	CONSUM.	MANG.	R	USO
FV-7-4M	180 x 22	5/8- 11	1.800 W	8.400	247	4	1.600	13	1/2	Intenso
FA-9C-4M	230 x 22	5/8- 11	1.800 W	5.900	385	4,7	1.650	13	1/2	Intenso
NAS-9BDS	230 x 22	5/8- 11	1.800 W	5.900	375	4,85	1.600	13	3/8	Intenso
FV-9BH-1M	230 x 22	5/8- 11	3.000 W	5.900	279	5,8	2.800	19	1/2	Intenso



Martillos y varios

05



Clavadoras y grapadoras	154
Sierras y limas	155
Limas, tijeras y podadora	157
Alicates y cuchillas	158
Biseladora y quitapuntos	162
Quitahunas	163
Cortadoras	164
Lijadora de cepillo y quita adhesivos	166
Martillos de agujas y kit martillos	167
Martillos y pisones	169
Cinceles	174
Máquinas electroportátiles	176



Clavadoras y grapadoras

► Todos los modelos se sirven en estuche

35/18

Grapadora de embalaje
(cartón)

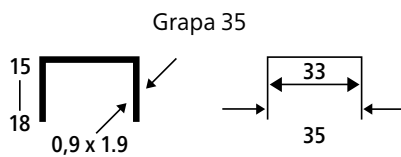

80/16PK

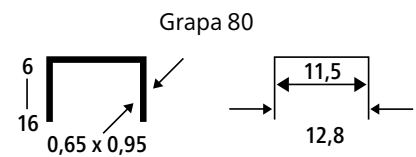

P08/30K

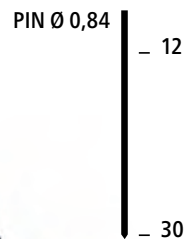

F18/50K

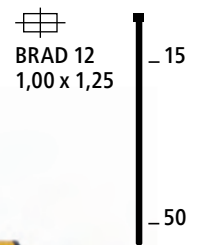

MODELO	TIPO	CORONA	ALAMBRE		CAPAC. CARRO	↔	KG	MANG.	ENTRADA AIRE	USO
			GROSOR	ALTURA						
35/18	Grapa 35	34,8	0,9 x 1,9	15 - 18	100	400	1,95	8	1/4	Ocasional
80/16PK	Grapa 80	12,9	0,95 x 0,65	6 - 16	160	225	0,9			Ocasional
P08/30K	Clavo Pin	-	0,84	12 - 30	140	230	1			Ocasional
F18/50K	Clavo	-	1,25 x 1	15 - 50	100	250	1,4			Ocasional



Clavadoras y grapadoras

► Los dos modelos se sirven en estuche

T-64K

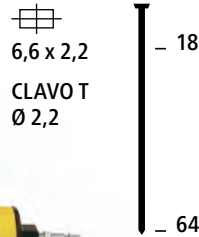

CF-15K

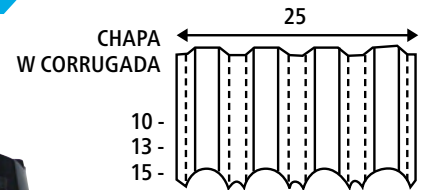

MODELO	TIPO	CORONA	ALAMBRE		CAPAC. CARRO	↔	KG	MANG.	ENTRADA AIRE	USO
			GROSOR	ALTURA						
T-64K	Clavo T	-	2,2	18 - 64	80	305	2,8	8	1/4	Ocasional
CF-15K	G.Corrug.	25,4	2,2	9 - 15	80	300	2,6			Ocasional



Sierras y limas

AS-11

Sierra

INCLUYE

Sierras 6600-24T y
6600-32T



AS-12

Lima-Sierra

INCLUYE

Juego de 4 limas y
sierras 6600-24T y
6600-32T



AS-5034

Lima-Sierra

INCLUYE

Juego de sierras
6600-24T, 6600-32T
y BW300-49A

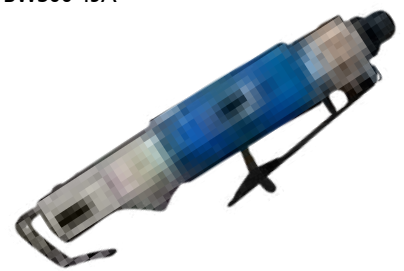

MODELO	CAPACIDAD CORTE		RECORRIDO HOJA	↔	RPM	KG	CONSUMO LIT / MIN	MANG.	R	USO
	ACERO	ALUM								
AS-11	1,6	1,6	10	230	10.000	0,6	250	8	1/4	Ocasional
AS-12	3	3	10	230	10.000	0,8	280	10		Continuo
AS-5034	3	3,8	10	280	9.000	0,6	368	10		Intenso



Sierras y limas

AF-10S

Lima-Sierra

INCLUYE

Juego de 3 limas y sierra
6600-32T



AS-15

Lima-Sierra

INCLUYE

Juego de 4 limas y sierras
66008-14T, 66008-18T y 66008-24T



LS300-F

Lima-Sierra

INCLUYE

Juego de 5 limas y sierras
6600-14T, 6600-18T y 6600-24T



HOJAS DE SIERRA

En paquetes de 10ud

MODELO	Nº DIENTES	HERRAMIENTA RECOMENDADA
6600-18T	18	AF-10S, AS-11, AS-12, LS300-F
6600-24T	24	AF-10S, AS-11, AS-12, LS300-F
6600-32T	32	AF-10S, AS-11, AS-12, LS300-F
BW300-49A	14	LS300-F
66008-14T	14	AS-15
66008-18T	18	AS-15
66008-24T	24	AS-15

6600



BW300



66008



- A menor nº de dientes cortan materiales más blandos.
- A mayor nº de dientes cortan materiales más duros.

MODELO	CAPACIDAD CORTE		RECORRIDO HOJA	↔	RPM	KG	CONSUMO LIT / MIN	MANG.	R	USO
	ACERO	ALUM								
AF-10S	3	3	10		5.500	0,8	280	10	1/4	Intenso
AS-15	8	10	20		5.500	0,7	280	10		Intenso
LS300-F	5	-	10		7.000	1,4	240	10		Intenso



Limas, tijera y podadora

LIMAS

Lima plana



Lima triangular



Lima redonda



Lima media caña



MODELO	HTA. RECOMENDADA
LP5	AF-10S
LP66008	AS-12, AS-15, LS300-F

MODELO	HTA. RECOMENDADA
LT5	AF-10S
LT66008	AS-12, AS-15, LS300-F

MODELO	HTA. RECOMENDADA
LR5	AF-10S
LR66008	AS-12, AS-15, LS300-F

MODELO	HTA. RECOMENDADA
LMC66008	AS-12, AS-15, LS300-F

PSH-10 • E-300 • E-300S

PSH-10



E-300S



E-300



MODELO	↔	KG	ENTRADA AIRE	CONS.	USO
PSH-10	225	1,2	1/4	450	Intenso

MODELO	ALUM	ACERO	GOMA	CUERO
E-300S	1,2	1,2	-	-
E-300	-	-	3	3

P66201

Podadora



MODELO	CAPACIDAD DE CORTE	↔	PESO	CONSUM. LIT / MIN	R	USO
P66201	25	250	0,68	0,73	1/4	Continuo

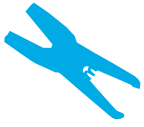

Alicates y cuchillas

MR

Alicate sin cuchillas

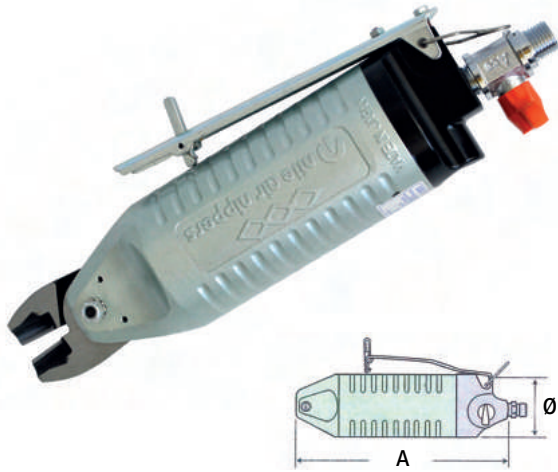

MP

Alicate sin cuchillas

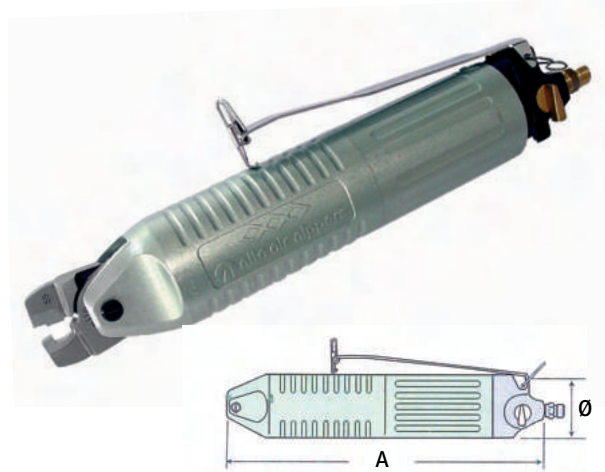

MR-M

Alicate sin cuchillas

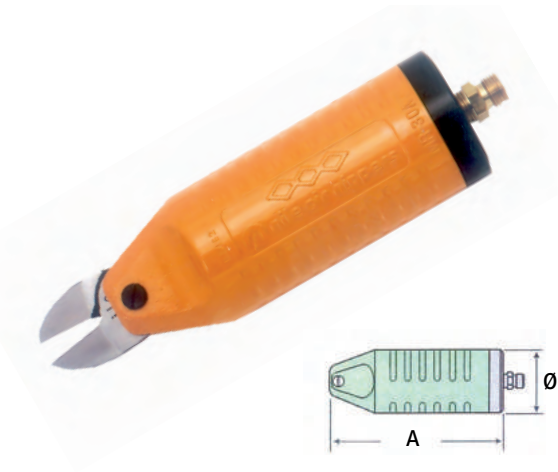

MS

Alicate sin cuchillas

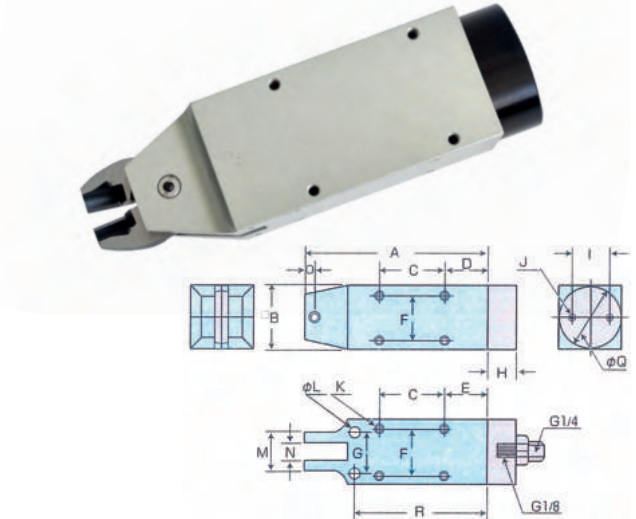

MODELO	A	Ø	KG
MR-5	103	30	0,14
MR-10	124	36	0,20
MR-20	155	45	0,34
MR-30A	191	56	0,52
MP-35A	268	56	0,83

MODELO	A	Ø	KG
MR-50A	256	75	1,29
MP-55A	372	75	2
MR-20M	121	45	0,27
MR-30AM	157	56	0,47
MP-35AM	249	56	0,79

MODELO	↔	Ø	KG	A	B	C	D	E	F	G	H	I	J	K	L	M	N	O	P	Q	R
MS-10	113	36	0,26	93	36	30	18	23	28	28	20	24	M4	M4	4,3	20	9	7	-	-	65
MS-20	129	45	0,43	109	45	40	19	24	36	30	20	30	M5	M4	5,3	26	12	9	-	-	81
MS-30	170	56	0,81	150	56	60	20	30	46	40	20	40	M6	M5	5,3	36	17	15	-	-	110



Alicates y cuchillas

Plástico

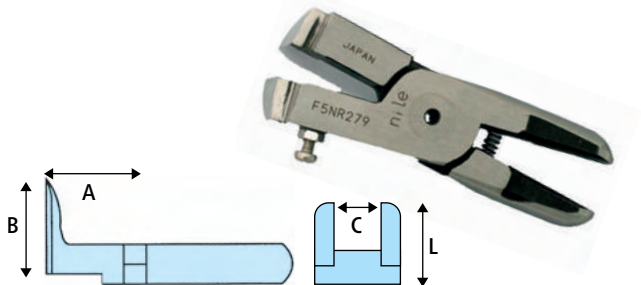

MODELO	PLÁSTICO	A	L	B	C	F°
F5NR325	7-5	40	30	15	10	90°
F5NR279	7-5	45	32	18	13	90°

Plástico

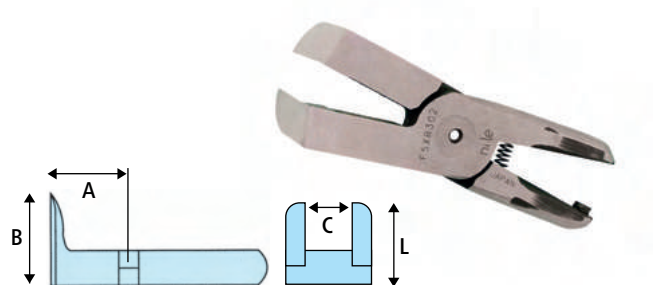

MODELO	PLÁSTICO	A	L	B	C	F°
F5XR302	7-5	50	48	33	10	90°
F9PNR322	13-10	65	60	40	14	90°

Plástico

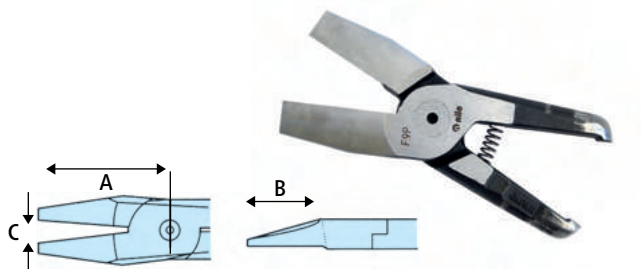

MODELO	PLÁSTICO. BLANDO-DURO	A	B	C	F°
F-1	2 - 1,0	24	12	3	15°
F-3	4 - 2,6	27	12	4,5	25°
F-5	7 - 5	35	15	8,5	15°
F-9P	13 - 6,5	65	38	15	15°

Plástico

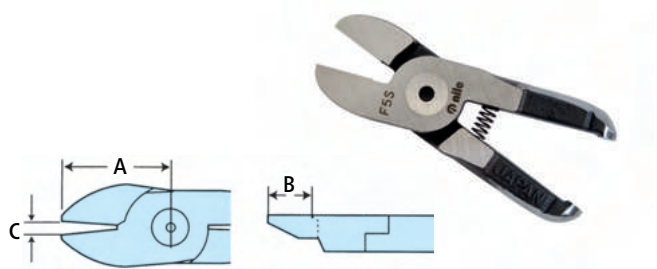

MODELO	PLÁSTICO. BLANDO-DURO	A	B	C	F°
F-3S	4 - 2,6	27	12	4,5	-
F-5S	7 - 5	35	16	8,5	-
F-5LS	7 - 5	65	35	14	-
F-9PS	13 - 6,5	65	37	15	-

Plástico

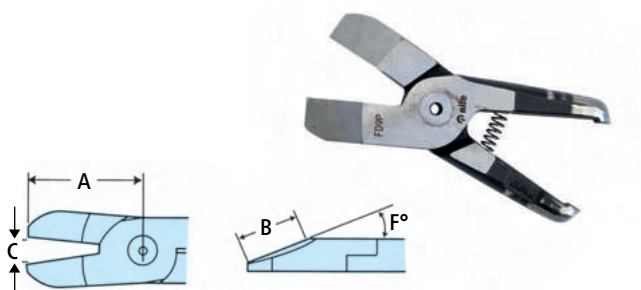

MODELO	PLÁSTICO. BLANDO-DURO	A	B	C	F°
FD-5	7 - 5	35	14	8,5	40°
FD-9P	13 - 6,5	59	27	14	30°

Metal

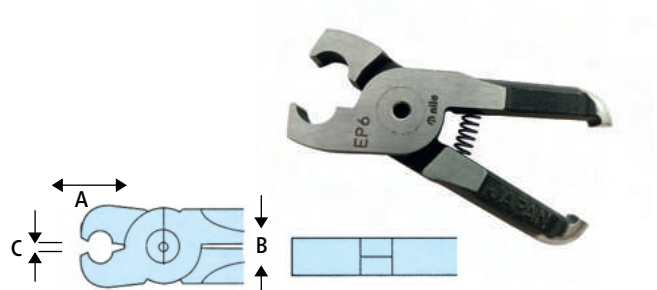

MODELO	ACERO	COBRE	A	B	C	F°
EP-6	2	2,6	28	12	5,5	-
EP-10P	2,8	3,3	34	17	5,5	-



Cuchillas

Metal cuchilla estandar

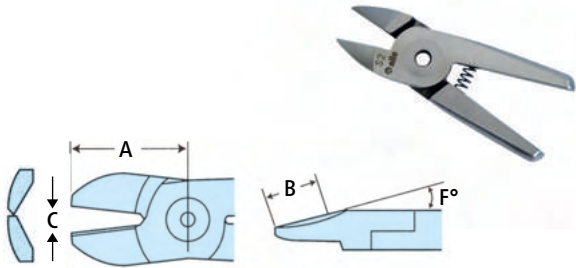

MODELO	ACERO	COBRE	A	B	C	F°
S-2	0,5	1,0	24	12	3	25°
S-4	1	1,6	27	14	5	25°
S-7P	2,8	3,3	43	20	7	30°

Metal cuchilla reforzada

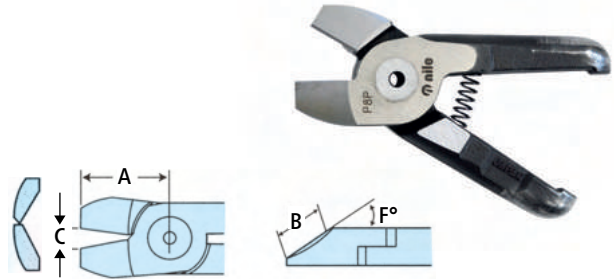

MODELO	ACERO	COBRE	A	B	C	F°
P-6	2	2,6	29	11	6	35°
P-8P	2,8	3,3	37	12	7	25°
P-120	4,5	5,5	40	16	8	35°

Metal cuchilla de Widia

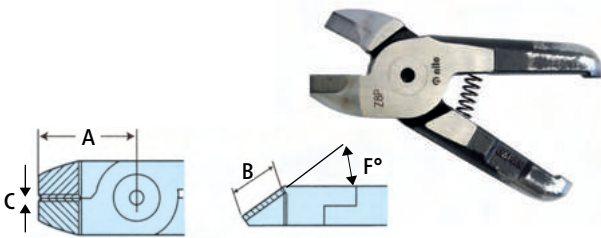

MODELO	ACERO	COBRE	A	B	C	F°
Z-2	0,5	1	24	11	3	25°
Z-4	1	1,6	27	10	5	25°
Z-6	2	2,6	30	15	6	35°
Z-8P	2,8	3,3	38	20	6	40°

Metal

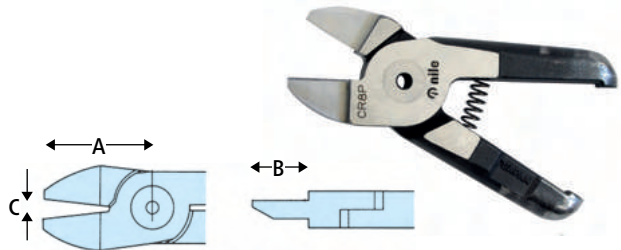

MODELO	ACERO	COBRE	A	B	C	F°
CR-6	2	2,6	35	15	7	-
CR-8P	2,8	3,3	43	20	7	-
CR-120	4,5	5,5	55	28	10	-

Engarzar

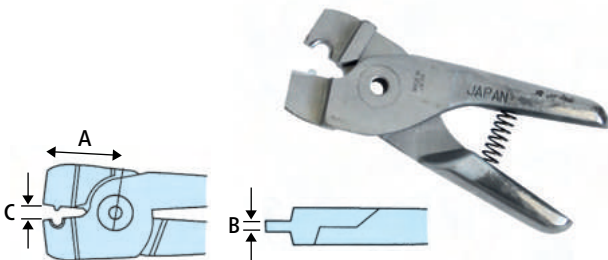

MODELO	ENGARZAR	A	B	C	F°
A-8P-2	2	31	5,8	6	-
A-8P-5,5	5,5	33	6	6,5	-
A-120	8	43	7	9	-

Engarzar

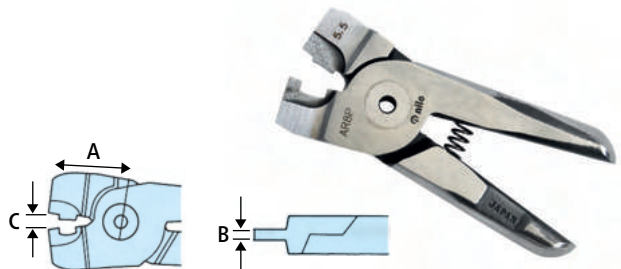

MODELO	ENGARZAR	A	B	C	F°
AR-8P-2	2	34	6,5	7	-
AR-8P-5,5	5,5	36	6,5	7	-



Cuchillas

CUCHILLA	MATERIAL RECOMENDADO (MM)						PARA ALICATE	
	BLANDO	DURO	ACERO	CUERDA-PIANO	COBRE	ENG		
S-2			0,5		1		MR-5	
Z-2			0,5	0,3	1			
F-1	2	1						
S-4			1		1,6		MR-10 MS-10	
Z-4			1	0,5	1,6			
F-3	4	2,6						
F-3S	4	2,6						
P-6			2		2,6		MR-20 MR-20M MS-20	
CR-6			2		2,6			
EP-6			2		2,6			
Z-6			2	1	2,6			
F-5	7	5						
F-5LS	7	5						
FD-5	7	5						
F-5S	7	5						
F5XR302	7	5						
F5NR325	7	5						
F5NR279	7	5						
P-8P			2,8		3,3			MR-30A / MR-30AM / MS-30
			2,8		4,8			MP-35A / MP-35AM
CR-8P			2,8		3,3			MR-30A / MR-30AM / MS-30
			2,8		4,8			MP-35A / MP-35AM
EP-10P			2,8		3,3			MR-30A / MR-30AM / MS-30
			2,8		4,8		MP-35A / MP-35AM	
S-7P			2,8		3,3		MR-30A / MR-30AM / MS-30	
			2,8		4,8		MP-35A / MP-35AM	
Z-8P			2,8	1,2	3,3		MR-30A / MR-30AM / MS-30	
				1,2	4,8		MP-35A / MP-35AM	
F-9P	13	6,5					MR-30A MR-30AM MS-30 MP-35A / MP-35AM	
FD-9P	13	6,5						
F-9PS	13	6,5						
F9PNR322	13	6,5						
A-8P-2						2	MR-30A / MR-30AM / MS-30	
						5,5	MP-35A / MP-35AM	
A-8P-5,5						2	MR-30A / MR-30AM / MS-30	
						5,5	MP-35A / MP-35AM	
AR-8P2						2	MR-30A / MR-30AM / MS-30	
						5,5	MP-35A / MP-35AM	
AR-8P-5,5						2	MR-30A / MR-30AM / MS-30	
						5,5	MP-35A / MP-35AM	
P-120			4,5	1,6	5,5		MR-50A	
			6	2	7		MP-55A	
CR-120			4,5	1,6	5,5		MR-50A	
			6	2	7		MP-55A	
A-120			4,5		5,5	8	MR-50A	
						8	MP-55A	



Biseladora y quitapuntos

210



721

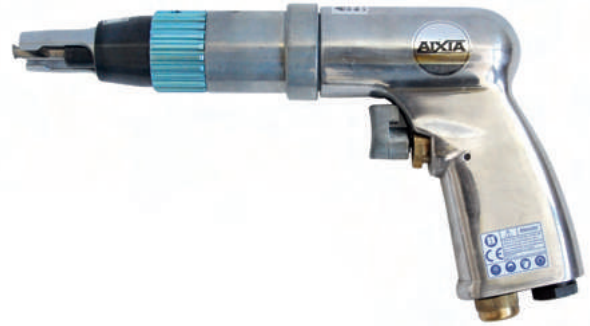

207

Presentado en estuche con brazo y 5 brocas



B-6T • B-8T

Brocas de titanio



MODELO	Ø	↔	PARA HTAS.
B-6T	6,5 mm	44 mm	207, 721
B-8T	8 mm	44 mm	207, 721

MODELO	EQUIPAMIENTO BROCAS	RPM	↔	KG	CONSUM.	MANG.	R	USO
210	1 de 8 mm	800	349	2,3	230	8	1/4	Intenso
721	1 de 8 mm	1.800	228	1,2	230			Continuo
207	2 de 6,5 mm y 3 de 8 mm	1.800	228	1,2	230			Intenso

1251BV

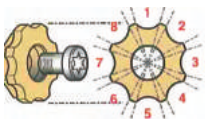

7211



MODELO	CAPACIDAD RADIO	RPM	↔	KG	CONSUM.	MANG.	R	USO
1251BV	2 - 3,5 R	7.500	280	2,8	600	10	1/4	Intenso
7211	3 R	28.000	135	0,5	57	10	1/4	Continuo

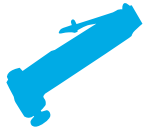

Quitalunas

208

Incluye: cuchilla D-140

208A

Incluye: cuchillas D-140, D-073, 6614-08-3A

QT100

Incluye: cuchilla D-140



CUCHILLAS

D-073

D-140

D-141

D-076

D-079

D-111

6614-08-3A

MODELO	↔
D-073	35 mm
D-140	57 mm
D-141	90 mm
D-076	24 mm
D-079	36 mm
D-111	95 mm
6614-08-3A	30 mm

MODELO	CUCHILLAS POSIBLES	RPM	↔	KG	CONSUM.	MANG.	R	USO
208	D-073, D-076, D-079, D-111, D-140, D-141, 6614-08-3A	20.000	215	1,3	250	8	1/4	Ocasional
208A			185					Continuo
QT100			195					0,97



Cortadoras

206

6031L



6031D

3011B

Disco protector giratorio 126°



MODELO	ACERO	FIBRA	Ø DISCO	KG	↔	RPM	CONSUM.	MANG.	R	USO
206	2	5	75	0,6	152	20.000	250	8	1/4	Ocasional
3011B	3	5	75	1,4	304	20.000	250			Continuo
6031L	2	-	51	1,2	245	620	250			Ocasional
6031D	-	5	51	1,2	245	7.000	250			Ocasional



Cortadoras

568



6031L-B1

Para metal

- Para hta 6031L



MOD.	Ø
6031L-B1	51

6031D-B1

Para fibra

- Para hta 6031D



MOD.	Ø
6031D-B1	51

209

Cuerpo en composite



- Su cabezal con 3 posibles facilita el corte en situaciones difíciles de acceso.

206D

Para metal

- Para 206, 3011B y 568



MOD.	Ø
206D	75

MODELO	ACERO	FIBRA	Ø DISCO	KG	↔	RPM	CONSUM.	MANG.	R	USO
568	2	5	75	1	210	15.000	400	8	1/4	Intenso
209	2	5	75	1,1	230	20.000	370	10	1/4	Continuo

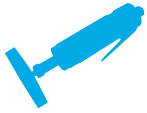

Lijadora de cepillo y quita adhesivos

6902K-3

Accesorios incluidos

6902K-3

Cepillo grueso curvo



MODELO	ANCHO CEPILLO	Ø ALAM.
L0723	23 mm	0,7
L0711	11 mm	0,7

Borrador



MODELO	Ø DISCO	TIPO
6902-D	110	Borrador

6034

Incluye disco borrador



Cepillo fino recto



MODELO	ANCHO CEPILLO	Ø ALAM.
R0523	23 mm	0,5
R0511	11 mm	0,5

Adaptador cepillo y borrador

BER100

Incluye disco borrador



MOD.	DESCRIPCIÓN
6902-A23	Adaptador ancho 23 mm
6902-A11	Adaptador ancho 11 mm

**6034
BER100**

Borrador



MODELO	Ø DISCO	TIPO
6034D-36	88	Borrador

MODELO	TIPO	Ø DISCO	ROSCA EJE	RPM	KG	CONSUM.	MANG.	R	USO
6902K-3	Lijadora de cepillo	100	-	3.500	1,1	400	10	1/4	Intenso
BER100	Borrador	85	5/16	2.500	1	370	10		Continuo
6034	Borrador	88	5/16	4.000	0,9	300	10		Ocasional



Martillos de agujas

FP-28CN

Incluye: 28 agujas de 3 mm
 • Opcional: 14 agujas de 4 mm



FP-35CN

Incluye: 19 agujas de 3 mm



F-25CN

Incluye: 19 agujas de 3 mm



FNS-2-1F

Incluye: 19 agujas de 3 mm



FNS-2P-1F

Incluye: 19 agujas de 3 mm



AGUJAS



AGUJA

RH63757	3 x 180
RH63757-04	4 x 180

AGUJA NORMA ATEX

AGUJA BERILIO	3 x 180
---------------	---------

MODELO	AGUJAS	Ø PISTÓN	CARRERA	Nº GOLPES	↔	KG	CONSUM.	MANG.	USO
FP-28CN	3 mm	26	29	3.500	350	3,6	350	10	Continuo
FP-35CN		23,5	20	3.700	330	2,7	300	10	Ocasional
F-25CN		25	22	4.000	410	2,6	200	10	Continuo
FNS-2-1F	3 mm	25	7	8.000	347	1,9	180	10	Intenso
FNS-2P-1F		25	7	8.000	309	2,5	180	10	Intenso



Kit martillos

830KH



Composición de cinces standar:

- 1 cincel plano pala 20 mm
- 1 cincel puntero
- 1 cincel de dos picos
- 1 cincel de corte
- 1 cincel V de dos picos
- 1 muelle retenedor R41012
- 1 muelle retenedor RCR

MUELLES, RETENEDORES Y ACOPLAMIENTO



ST-NS11A-H
Acoplamiento para agujas
P/830KH - 850KH - 840KH

850KH



Composición de cinces standar:

- 1 cincel plano pala 20 mm
- 1 cincel puntero
- 1 cincel de dos picos
- 1 cincel de corte
- 1 cincel V de dos picos
- 1 muelle retenedor R41012
- 1 muelle retenedor RCR



R2215-17A
Muelle retenedor (840KH)

R41012
Muelle retenedor



R2215-17B
Muelle retenedor cónico

840KH \square 10 • 841KRD \circ 10



Composición de cinces standar:

- 1 cincel plano pala 20 mm
- 1 cincel puntero
- 1 cincel de dos picos
- 1 cincel de corte
- 1 cincel V de dos picos
- 1 muelle retenedor R2215-17C



RCR
Retenedor de cinces



R2215-17C
Muelle retenedor

MODELO	CINCEL TIPO	C.REMAC ALU-ACER	Ø PISTÓN	CARRE.	Nº GOLPES	↔	KG	CONSUM.	MANG.	USO
830KH	\square 10	6, 4 - 5	19	96	2.100	280	2,6	450	10	Continuo
850KH				103	2.200	260	1,9	450		Continuo
840KH				45	2.500	170	1,5	300		Continuo
841KRD				\circ 10	45	3.000	193	1,5		400



Martillos

FP-20

Incluye cincel FP20/25C

 12,6 mm

FP-30

Baja vibración

 10 mm

F-25
 12,7 mm

FCH-20-1F

Incluye cincel G-2-1

 11 mm

FCH-25-1F

Incluye cincel F-3-3

 12,7 mm

MODELO	CINCEL	Ø PISTÓN	CARRERA	Nº GOLPES	↔	KG	CONSUM.	MANG.	USO
FP-20	<input type="checkbox"/> 12,6	23,5	73	2.700	295	2,6	300	10	Continuo
FP-30	<input type="checkbox"/> 10	19	58	3.500	242	2,2	400	10	Continuo
F-25	<input type="checkbox"/> 12,7	25	22	4.000	190	1,5	300	10	Continuo
FCH-20-1F	<input type="checkbox"/> 11	20	16	12.000	201	1	140	8	Intenso
FCH-25-1F	<input type="checkbox"/> 12,7	25	20	8.000	220	1,5	180	10	Intenso



Martillos

FRH-3-1
 8,7 mm

FRH-6-1
 8,7 mm

FRH-6A-1
 8,7 mm

MODELO	CINCEL TIPO	C.REMAC ALU-ACER	Ø PISTÓN	CARRE.	Nº GOLPES	↔	KG	CONSUM.	MANG.	USO
FRH-3-1	 8,7	3,2 - 2,5	14,3	38	3.600	136	1,1	350	10	Intenso
FRH-6-1	 8,7	6,4 - 5	12,7	100	1.800	197	1,4	350		Intenso
FRH-6A-1	 8,7	6,4 - 5	20	45	3.000	193	1,5	400		Intenso



Martillos

FRH-6-2
 10,2 mm

**FRH-3-1
FRH-6-1 • FRH-6-2**

MODELO	H019715-00
--------	------------

**FRH-6A-1
FRH-6A-2**

MODELO	H024715-00
--------	------------

FRH-6A-2
 10,2 mm

**FRH-3-1
FRH-6-1 • FRH-6-2**

MODELO	H019719-00
--------	------------

**FRH-6A-1
FRH-6A-2**

MODELO	H024719-01
--------	------------

MODELO	CINCEL TIPO	C.REMAC ALU-ACER	Ø PISTÓN	CARRE.	Nº GOLPES	↔	KG	CONSUM.	MANG.	USO
FRH-6-2	○ 10,2	6,4 - 5	12,7	100	1.800	197	1,4	350	10	Intenso
FRH-6A-2	○ 10,2	6,4 - 5	20	45	3.000	193	1,5	400		Intenso



Martillos

FC-01/K

12 mm



FC-1Z/K

14,8 mm



FC-2Z/K

14,8 mm



FC-4Z/K

14,8 mm



MODELO	CINCEL	Ø PISTÓN	CARRERA	Nº GOLPES	↔	KG	CONSUMO	MANG.	R	USO
FC-01/K	12	20	45	3.000	243	2,6	400	10	1/4	Continuo
FC-1Z/K	14,8	28,5	25	3.000	300	5	600	13	3/8	Continuo
FC-2Z/K	14,8	28,5	51	2.500	342	5,7	600	13	3/8	Continuo
FC-4Z/K	14,8	28,5	102	1.700	424	8,1	650	13	3/8	Continuo



Martillos y pisones

FC-01-3

 12 mm



FC-1Z-1

 14,8 mm



FC-4Z-1

 14,8 mm



LATIGUILLO ANTIVIBRATORIO



Recomendamos el uso de este accesorio para evitar la transmisión directa de la vibración desde la manguera al enchufe, evitando de esta manera el deterioro de la válvula y la consecuente pérdida involuntaria de aire.

Aconsejamos su uso en pistolas de impacto y martillos (cinceladores, de agujas...)

MODELO	R.	SERIE DEL ENCHUFE	Ø MANG.
LAT 1/4 - 24	1/4	24	10
LAT 1/4 - 26	1/4	26	10
LAT 3/8 - 26	3/8	26	10
LAT 3/8 - 30	3/8	30	10
LAT 1/2 - 30	1/2	30	13
LAT 1/2 - 37	1/2	37	13

MODELO	CINCEL	Ø PISTÓN	CARRERA	Nº GOLPES	↔	KG	CONSUMO	MANG.	R	USO
FC-01-3	 12	20	45	3.000	243	2,6	400	10	1/4	Intenso
FC-1Z-1	 14,8	28,5	25	3.000	300	5	600	13	3/8	Intenso
FC-4Z-1	 14,8	28,5	102	1.700	424	6,9	650	13	3/8	Intenso

FR-0 • FR-00



FR-1 • FR-2 • FR-0L



MODELO	Ø MAZA	Ø PISTÓN	CARRERA	Nº GOLPES	↔	KG	CONSUMO	MANG.	R	USO
FR-00	40	18	50	1.800	440	1,5	400	10	3/8	Intenso
FR-0	52	22	65	1.000	520	3	500	10	3/8	Intenso
FR-0L	52	22	65	1.000	1.050	4	500	10	3/8	Intenso
FR-1	67	25	100	800	1.220	7	700	13	1/2	Intenso
FR-2	75	32	127	700	1.300	10	800	13	1/2	Intenso



Cinceles

FRH-3-1
FRH-6-1 • FRH-6A-1

8,7 mm

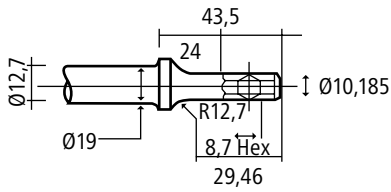

FRH-6-2
FRH-6A-2 • 841KRD

10,2 mm

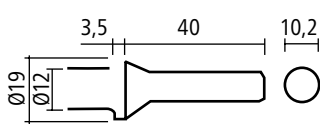

840KH • FP-30
830KH • 850KH

10 mm

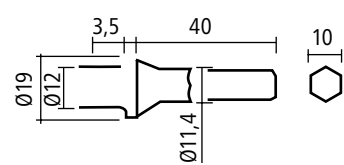

MODELO	AxL
 WA-807H	16x155
 WA-808H	15x170
 WA-809H	20x170
 WA-812H	170
 WA-810H	18x170
 WA-810HA	32x170
 WA-813H	19x170
 WA-815H	19x150

MODELO	AxL
 WA-807	16x155
 WA-808	15x170
 WA-809	20x170
 WA-810	20x178
 WA-812	170
 WA-815	20x150
 WA-803	Horquilla

MODELO	AxL
 84671H	16x140
 84677H	22x165
 84663H	140
 84662H	20x175
 84662HA	33x140
 84675H	20x165



Cinceles

FC-01 • FC-01-3

12 mm

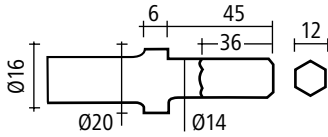

MODELO	AxL
WJB-10P	250
WJB-10F	16x250
WJB-10SL	30x250

FC-1Z • FC-2Z FC-4Z

14,8 mm

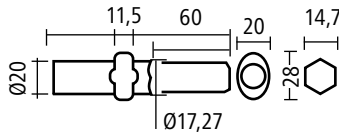

MODELO	AxL
CO15H00P260	260
CO15H25F260 CO15H32F260 CO15H32F305	25X260
	32x250
	32X305

FP-20

12,6 mm

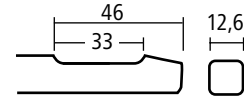

MODELO	AxL
FP20/1	180
FP20/35	35 x 175
FP20/25C	35 x 180

FC-1Z-1 • FC-4Z-1

14,8 mm

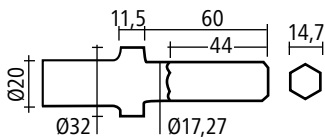

MODELO	AxL
WH-10P	250
WH-10F	25x250
WH-10SL	31x250

FCH-25-1F

12,7 mm

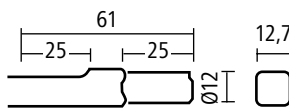

MODELO	AxL
F-2-3/19 F-2-3/35	19 x 180
F-3-3	34 x 175

F-25

12,7 mm

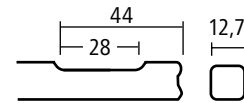

MODELO	AxL
F25-2	19 x 180
F25-3	35 x 180

FCH-20-1F

11 mm

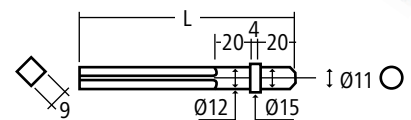

MODELO	AxL
G-2-1	9 x 130
S-1	180



Máquinas electroportátiles

BT-B5201241-40A

Taladro percutor-atornillador



Maletín con 2 baterías y cargador

- ▶ Motor sin escobillas.
- ▶ CAPACIDAD: 13 mm acero, 65 mm madera, 16 mm hormigón.
- ▶ Portabrocas desmontable, conexión 1/4 hexágono para puntas.
- ▶ Selector de función
■ taladro o ■ martillo
- ▶ Selector de velocidad.
- ▶ Gatillo con control de velocidad variable.
- ▶ Empuñadura ergonómica en goma.
- ▶ Indicador de carga de batería.



MODELO	VOLTAJE	CAPACIDAD DE BROCA	VELOCIDAD R.P.M		GOLPES MIN	POTENCIA NM	KG	DIMENSIÓN	BATERIA	CARG
			MAX	MIN						
BT-B5201241-40A	DC 20V	13 mm	1.950	600	39.600	135	2,39	205x65x210	BP2040S31	BC20S31



Máquinas electroportátiles

BC20S31

Cargador



MODELO	V ENTRADA	V SALIDA
BC20S31	AC220	DC20V

BP2040S31

Batería



MODELO	VOLTAJE	AMPERIOS
BP2040S31	20 V	4Ah

Enchufes rápidos



- ✓ Instale un FR+L en cada toma donde vaya a conectar la herramienta que garantice un aire limpio de impurezas, lubricado y a la presión adecuada.
- ✓ La presión en la herramienta para lograr un rendimiento óptimo de la misma debe ser de 6,3 bar. Verifique periódicamente que el elemento filtrante esté limpio de impurezas, que la purga y el lubricador funcionan correctamente, y reponga el nivel de aceite si fuera necesario.
- ✓ Instale una llave paso en la entrada del FR+L, le será útil cuando tenga que reparar o sustituir el FR+L o algún elemento posterior. Cuando abra la válvula, hágalo de forma gradual para evitar los golpes de ariete.

Instalación, filtraje y lubricación



- ✓ Todo nuestro sistema de aire, desde el compresor hasta la herramienta, tiene un solo fin, conseguir el máximo rendimiento de la herramienta con el menor coste posible. Según el enchufe rápido que utilice, puede facilitararlo o impedirlo.
- ✓ Un enchufe rápido con válvula ULTRAFLO tiene un rendimiento hasta un 80 % superior respecto de otro con válvula convencional, mejorando notablemente el rendimiento de la herramienta. Una caída de presión de 1 bar supone reducir el rendimiento de la herramienta hasta un 26 %.
- ✓ Evite las fugas de aire sustituyendo las piezas dañadas.
- ✓ Un enchufe de seguridad o antilatigazo a la salida de los FR+L le evitará accidentes y facilitará la desconexión con presión.
- ✓ Utilice enchufes con válvula ULTRAFLO (series 23, 1400, 23KE, 25, 1600, 25KE, 1600KE, 1700), le aportarán mayor paso de aire con mínima caída de presión, así optimizará los rendimientos de su herramienta y de su instalación de aire.
- ✓ Coloque un latiguillo de 0,5 m entre la herramienta y la conexión del enchufe rápido, de esta forma evitará que se transmita la vibración de la herramienta al enchufe y dañe la válvula del mismo, provocando fugas de aire.

Mangueras

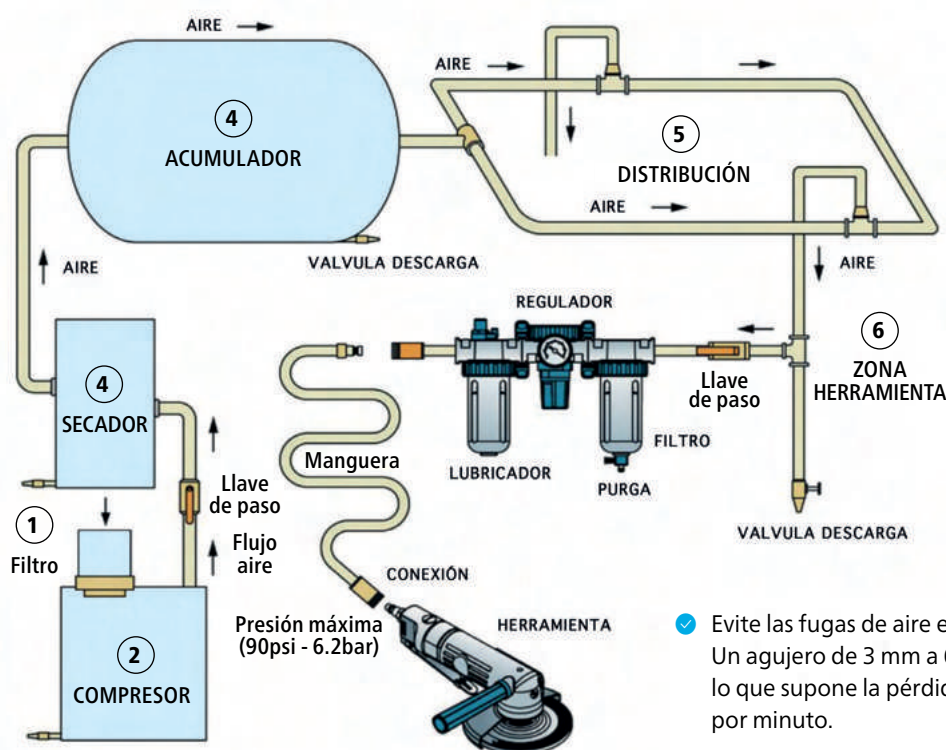

- ✓ Utilice mangueras de diámetro adecuado; si es pequeño, caerá la presión y reducirá sensiblemente el rendimiento de la herramienta, acelerará su desgaste y empleará más tiempo en realizar el trabajo.
- ✓ Evite las fugas de aire en mangueras y uniones. Un agujero de 3 mm a 6 bar, deja escapar 600 lt/m, lo que supone la pérdida innecesaria de 4,2 C.V. por minuto.



Tarifa de precios

- ✓ Esta tarifa sustituye y anula todas las anteriores.
- ✓ Los precios de esta tarifa son para la mercancía puesta en nuestros almacenes de Abadiano y no incluyen el IVA.
- ✓ AIXIA, S.A. se reserva el derecho de efectuar modificaciones de la misma, sin previo aviso.
- ✓ Las condiciones de venta aquí reflejadas son aceptadas, cuando el cliente formaliza su pedido a AIXIA, S.A.

Transporte

- ✓ Los pedidos por valor superior a 450 € netos, y dentro de la península, serán enviados a portes pagados. Para valores inferiores, si el cliente no indica lo contrario, el pedido se enviará por nuestra agencia con portes cargados en la factura.
- ✓ Se recomienda comprobar el buen estado de la mercancía en su recepción, en caso contrario reclamar inmediatamente al transportista.
- ✓ Cualquier reclamación sobre la calidad o cantidad de la recepción deberá hacerse por escrito y como máximo a los tres días de la recepción, explicando motivos.

Devoluciones de material

- ✓ Toda mercancía devuelta deberá hacerse a portes pagados y pertenecer a la tarifa en vigor. No se aceptarán devoluciones de material transcurridos 10 días desde su envío, que no aparezca en el catálogo vigente, ni de máquinas, accesorios o repuestos que hayan sido modificados a petición del cliente. Las devoluciones deben ser notificadas previamente por escrito y AIXIA S.A. aceptarlas.
- ✓ En caso de recepción en mal estado del material, empaque y/o documentación, AIXIA se reserva el derecho de no aceptar la devolución o descontar la parte correspondiente que se estime.

Forma de pago

- ✓ El plazo máximo de pago será de 60 días desde la fecha de la emisión de la factura. Cualquier pago no atendido en la fecha de vencimiento, ocasionará el bloqueo del crédito hasta que el pago sea efectuado en su totalidad.

Garantía

- ✓ Nuestros productos tienen una garantía de 12 meses contra todo defecto de fabricación, siempre que se hayan usado correctamente y se hayan seguido las instrucciones de uso y mantenimiento que se adjuntan con cada herramienta, y la misma no haya sido manipulada o instalada inadecuadamente.
- ✓ Las averías causadas por humedad, suciedad, presión inadecuada o desgaste, no serán objeto de garantía.
- ✓ Las reparaciones tienen una garantía de 3 meses sobre las piezas sustituidas, excepto los rodamientos.

Presupuestos de reparación

- ✓ Si el importe de la reparación no supera el 25% del valor de la máquina, se reparará sin presupuesto previo.
- ✓ Se procederá a la devolución de las máquinas (desmontadas) de los presupuestos enviados y no contestados en el plazo de 3 semanas. Los portes serán a cargo del cliente.

Jurisprudencia

- ✓ Todo producto suministrado por AIXIA, S.A. será propiedad de AIXIA, S.A. hasta que sea efectuado el pago íntegro del mismo.
- ✓ En caso de discrepancias, las partes se someterán a los tribunales de Durango, renunciando el cliente a cualquier otro fuero.

Manual de instrucciones y seguridad

- ✓ Por su seguridad, antes de usar la herramienta, lea y entienda el manual de instrucciones y seguridad que se entrega con cada herramienta.
- ✓ Desconecte la herramienta del aire al finalizar el trabajo, al cambiar el accesorio o cuando vaya a repararla.
- ✓ Proteja la cabeza, cara, ojos, oídos, manos y pies cuando sea necesario y utilice ropa adecuada al trabajo.
- ✓ Si debido a la vibración de la herramienta siente molestias en manos o brazos, detenga su uso y visite al médico antes de reanudar el trabajo.



Nuestros servicios



Envíos en 24 h



Servicio técnico

Reparación en 24/48h
Reparación de herramientas

Envíanos a reparar tu herramienta Aixia o de otra marca y en caso de no tener reparación te ofertamos una Aixia a un precio especial.



Atención y asesoramiento técnico personalizado

AIXIA

aixia.es

Pol. Ind. Astola, C/ Eulena 1B
48220 ABADIANO (BIZKAIA)
T. 94 620 17 08
aixia@aixia.es

Ciudad de Frías 5, Nave 5
Pol. Ind. Camino de Getafe
28021 MADRID
T. 91 505 13 20
F. 91 505 39 52
aixiamadrid@aixia.es

Marqués del Nervión 54
41005 SEVILLA
T. 95 458 12 22
F. 95 458 11 88
aixiasevilla@aixia.es

Carrer dels Carreters 19 B - P.I.dels Oficis
46950 XIRIVELLA (VALENCIA)
T. 96 349 73 37
F. 96 347 82 72
aixialevante@aixia.es